

# CONTROL DEVICES

## 1. CAB DEVICES

1) The ergonomically designed console box and suspension type seat provide the operator with comfort.

### 2) ELECTRONIC MONITOR SYSTEM

- (1) The centralized electronic monitor system allows the status and conditions of the machine to be monitored at a glance.
- (2) It is equipped with a safety warning system for early detection of machine malfunction.

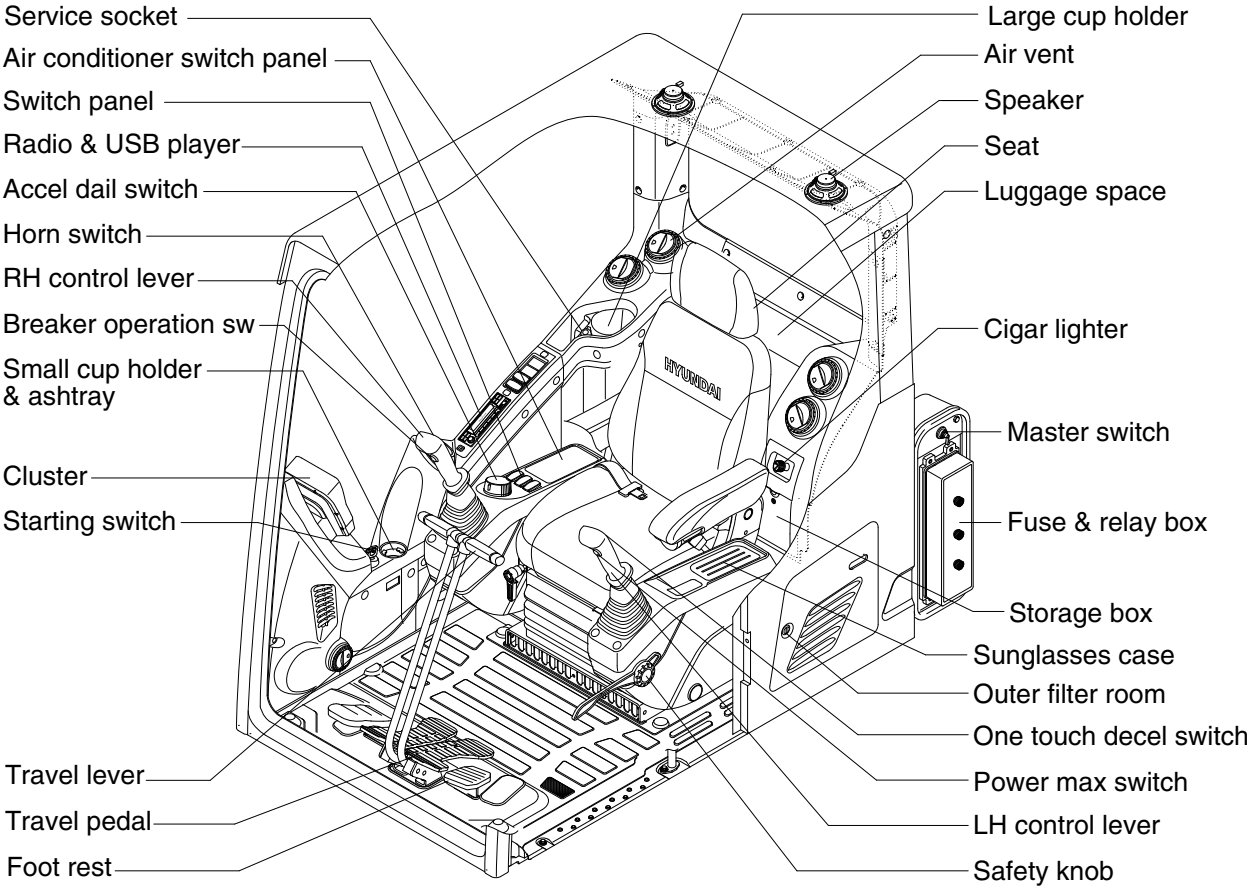

400S3CD01

## 2. CLUSTER

### 1) STRUCTURE

The cluster consists of LCD and switches as shown below. The LCD is to warn the operator in case of abnormal machine operation or conditions for the appropriate operation and inspection.

The LCD is to set and display for modes, monitoring and utilities with the switches.

The switches or touch screen are to set the machine operation modes.

※ The cluster installed on this machine does not entirely guarantee the condition of the machine. Daily inspection should be performed according to chapter 6, Maintenance.

※ When the cluster provides a warning immediately check the problem, and perform the required action.

#### Normal type



220S3CD501A

#### Premium type



220S3CD01B

※ The warning lamp pops up and/or blinks and the buzzer sounds when the machine has a problem. The warning lamp blinks until the problem is cleared. Refer to page 3-6 for details.

## 2) GAUGE

### (1) Operation screen

When you first turn starting switch ON, the operation screen will appear.

#### Normal type



220S3CD551A

#### Premium type

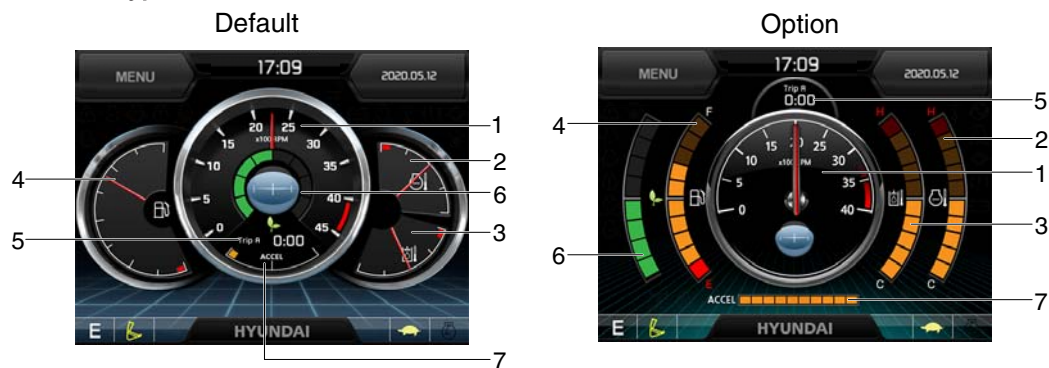

220S3CD151A

- |                                    |                     |
|------------------------------------|---------------------|
| 1 RPM / Speed gauge                | 5 Tripmeter display |
| 2 Engine coolant temperature gauge | 6 Eco gauge         |
| 3 Hydraulic oil temperature gauge  | 7 Accel dial gauge  |
| 4 Fuel level gauge                 |                     |

※ Operation screen type can be set by the screen type menu of the display (premium type). Refer to page 3-30 for details.

### (2) RPM / Speed gauge

#### Normal type



① This displays the engine speed.

#### Premium type



220S3CD549

### (3) Engine coolant temperature gauge



Normal type

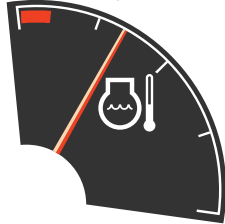

Premium type



220S3CD553

- ① This gauge indicates the temperature of coolant.
    - White range : 40-113°C (104-235°F)
    - Red range : Above 113°C (235°F)
  - ② If the indicator is in the red range or  lamp pops up and the buzzer sounds, turn OFF the engine and check the engine cooling system.
- ※ If the gauge indicates the red range or  lamp blinks in red even though the machine is in the normal condition range, check the electric device as this can be caused by poor connection of sensor.

### (4) Hydraulic oil temperature gauge



Normal type



Premium type



220S3CD554

- ① This gauge indicates the temperature of hydraulic oil.
    - White range : 40-100°C (104-212°F)
    - Red range : Above 100°C (212°F)
  - ② If the indicator is in the red range or  lamp pops up and the buzzer sounds reduce the load on the system. If the gauge stays in the red range, stop the machine and check the cause of the problem.
- ※ If the gauge indicates the red range or  lamp blinks in red even though the machine is in the normal condition range, check the electric device as this can be caused by poor connection of electricity or sensor.

### (5) Fuel level gauge



Normal type

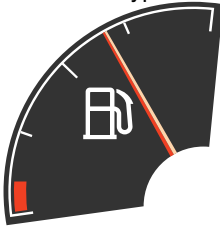

Premium type



220S3CD555

- ① This gauge indicates the amount of fuel in the fuel tank.
  - ② Fill the fuel when in the red range, or  lamp pops up and the buzzer sounds.
- ※ If the gauge indicates the red range or  lamp blinks in red even though the machine is on the normal condition range, check the electric device as this can be caused by poor connection of electricity or sensor.

### (6) Tripmeter display

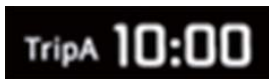

290F3CD56

- ① This displays the engine the tripmeter.
- ※ Refer to page 3-31 for details.

### (7) Eco gauge



290F3CD58

- ① This gauge indicates the fuel consumption rate and machine load status so that the operators can operate the machine efficient in regards to fuel consumption.
- ② Fuel consumption rate or machine load is higher if the number of segments are increased.
- ③ The color of Eco gauge indicates operation status.
  - White : Idle operation
  - Green : Economy operation
  - Yellow : Non-economy operation at a medium level.
  - Red : Non-economy operation at a high level.

### (8) Accel dial gauge



290F3CD59

- ① This gauge indicates the level of accel dial.

### 3) WARNING LAMPS

#### Normal type





400SA3CD503

#### Premium type



400SA3CD03

#### ※ Warning lamps and buzzer







Warnings	When error happened	Lamps and buzzer
All warning lamps except below	Warning lamp pops up on the center of the LCD and the buzzer sounds	<ul style="list-style-type: none"> <li>The pop-up warning lamp moves to the original position, blinks and the buzzer stops when;                             <ul style="list-style-type: none"> <li>- the buzzer stop switch  is pushed</li> <li>- the lamp of the LCD is touched</li> </ul> </li> </ul>
	Warning lamp pops up on the center of the LCD and the buzzer sounds	<ul style="list-style-type: none"> <li>Cluster displays this pop-up when it has communication error with MCU.</li> <li>If communication with MCU become normal state, it will disappear automatically.</li> </ul>
	Warning lamp pops up on the center of the LCD and the buzzer sounds	※ Refer to page 3-7 for details.

※ Refer to page 3-13 for the buzzer stop switch .

### (1) Engine coolant temperature warning lamp









290F3CD61

- ① Engine coolant temperature warning is indicated in 2 steps.
  - 100°C over : The  lamp pops up and the buzzer sounds.
  - 107°C over : The  lamp pops up and the buzzer sounds.
- ② The pop-up ,  lamps move to the original position and blinks when the buzzer stop switch  is pushed. The buzzer will stop and ,  lamps will blink.
- ③ Check the cooling system when the lamps keep blink.

### (2) Hydraulic oil temperature warning lamp



290F3CD62

- ① Hydraulic oil temperature warning is indicated in 2 steps.
  - 100°C over : The  lamp pops up and the buzzer sounds.
  - 105°C over : The  lamp pops up and the buzzer sounds.
- ② The pop-up ,  lamps move to the original position and blinks when the buzzer stop switch  is pushed. The buzzer will stop and ,  lamps will blink.
- ③ Check the hydraulic oil level and hydraulic cooling system.

### (3) Fuel level warning lamp

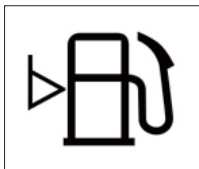

290F3CD63

- ① This warning lamp pops up and the buzzer sounds when the fuel level is below 23 ℓ (6.1 U.S. gal).
- ② Fill the fuel immediately after the lamp blinks.

### (4) Emergency warning lamp



290F3CD64

- ① This warning lamp pops up and the buzzer sounds when each of the below warnings occurs.
  - Engine coolant overheating (over 107°C)
  - Hydraulic oil overheating (over 105°C)
  - MCU input voltage abnormal
  - Cluster communication data error
  - Engine ECM communication data error
- ※ The pop-up warning lamp moves to the original position and blinks when the buzzer stop switch  is pushed. The buzzer will stop.
- ② When this warning lamp blinks, machine must be checked and serviced immediately.

#### (5) Engine oil pressure warning lamp

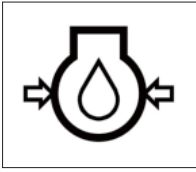

290F3CD65

- ① This warning lamp pops up and the buzzer sounds when the engine oil pressure is low.
- ② If the lamp blinks, shut OFF the engine immediately. Check oil level.

#### (6) Battery charging warning lamp

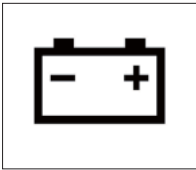

290F3CD67

- ① This warning lamp pops up and the buzzer sounds when the battery charging voltage is low.
- ② Check the battery charging circuit when this lamp blinks.

#### (7) Air cleaner warning lamp



290F3CD68

- ① This warning lamp pops up and the buzzer sounds when the air cleaner is clogged.
- ② Check, clean or replace filter.

#### (8) Overload warning lamp (opt)



290F3CD69

- ① When the machine is overloaded, the overload warning lamp pops up and the buzzer sounds when the overload switch is ON. (if equipped)
- ② Reduce the machine load.

#### (9) Coolant level warning lamp

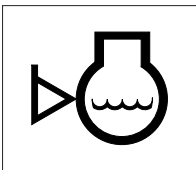

760F3CD58

- ① This warning lamp indicates lack of coolant.
- ② Check and refill coolant.



#### 4) PILOT LAMPS

##### Normal type















400SA3CD574

##### Premium type



400SA3CD74

### (1) Mode pilot lamps

No	Mode	Pilot lamp	Selected mode
1	Power mode		Heavy duty power work mode
			Standard power mode
			Economy power mode
2	User mode		User preferable power mode
3	Work tool mode		General operation - IPC speed mode
			General operation - IPC balance mode
			General operation - IPC efficiency mode
			Breaker operation mode
			Crusher operation mode
4	Travel mode		Low speed traveling
			High speed traveling
5	Auto idle mode		Auto idle

### (2) Power max pilot lamp (null)



290F3CD78

- ① The lamp will be ON when pushing power max switch on the LH RCV lever.
  - ② The power max function operates for a max period of 8 seconds.
- ※ Refer to page 3-35 for power max function.

### (3) Warming up pilot lamp

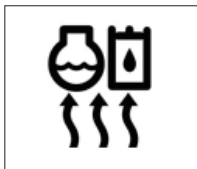

290F3CD80

- ① This lamp lights up when the coolant temperature is below 30°C (86°F).
- ② The automatic warming up is cancelled when the engine coolant temperature is above 30°C (86°F), or when 10 minutes have passed since starting the engine.

#### (4) Decel pilot lamp



290F3CD81

- ① Operating one touch decel switch on the RCV lever makes the lamp light up.
  - ② Also, the lamp will light up. And engine speed will be reduced automatically to save fuel when all levers and pedals are in the neutral position, and the auto idle function is selected.
- ※ **One touch decel is not available when the auto idle pilot lamp is turned ON.**
- ※ **Refer to page 3-35.**

#### (5) Fuel warmer pilot lamp

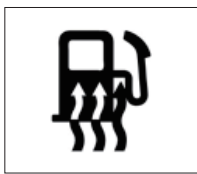

290F3CD82

- ① This lamp lights up when the coolant temperature is below 10°C (50°F) or the hydraulic oil temperature 20°C (68°F).
- ② The automatic fuel warming is cancelled when the engine coolant temperature is above 60°C (140°F), and the hydraulic oil temperature is above 45°C (113°F) since the start switch was ON position.

#### (6) Maintenance pilot lamp



290F3CD83

- ① This lamp lights up when consumable parts are in need of replacement. It means that the change or replacement interval of parts is 30 hours from the required change interval.
  - ② Check the message in maintenance information of main menu. Also, this lamp lights up for 3 minutes when the start switch is switched to the ON position.
- ※ **Refer to page 3-24.**

#### (7) Smart key pilot lamp (premium type, opt)

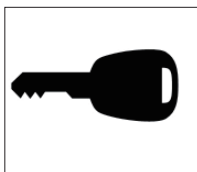

290F3CD214

- ① This lamp lights up when the engine is started by the start button.
  - ② This lamp is red when the authentication fails, it will be green when it authentication is successful.
- ※ **Refer to page 3-25.**

#### (8) Auto engine shutdown pilot lamp (premium type, opt)



220A3CD202A

- ① This lamp lights up when the auto engine shutdown is activated
- ※ **Refer to page 3-21.**

## 5) SWITCHES

### Normal type



220S3CD586A

### Premium type



220S3CD86B

※ When some of the switches are selected, the pilot lamps are displayed on the LCD. Refer to the page 3-9 for details.

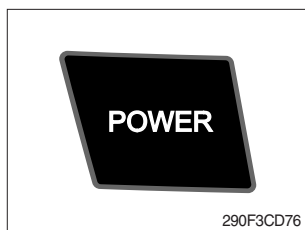

### (1) Power mode switch

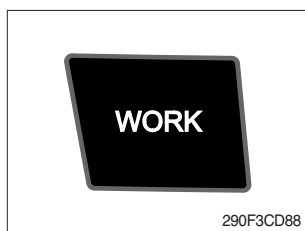

- ① This switch is to select the machine power mode and when pressed, the power mode pilot lamp will be displayed on the section of the monitor.
  - P : Heavy duty power work.
  - S : Standard power work.
- ② · E : Economy power work.  
The pilot lamp changes E → S → P → E in this order.

### (2) Work mode switch



- ① This switch is to select the machine work mode, which shifts from general operation mode to optional attachment operation mode.
    -  : General operation mode
    -  : Breaker operation mode (if equipped)
    -  : Crusher operation mode (if equipped)
    - Not installed : Breaker or crusher is not installed.
- ※ Refer to the page 2-7 for details.

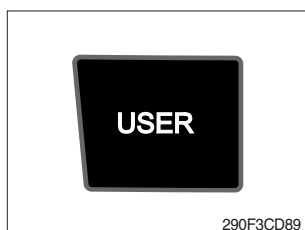

### (3) User mode switch

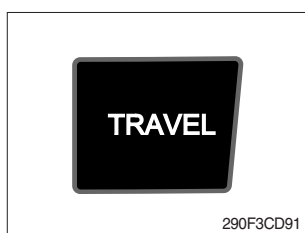

- ① This switch is used to select between user mode and general power mode.
  - U : User mode
  - P/S/E : General power mode
- ② Refer to the page 3-19 for another set of user mode.

### (4) Travel speed switch



- ① This switch is used to select the travel speed alternatively.
    -  : Low speed
    -  : High speed
- ※ Do not change the setting of the travel speed switch while machine is moving. Machine stability may be adversely affected
- ▲ Serious injury or death can result from sudden changes in machine stability.

### (5) Auto idle/ buzzer stop switch



- ① This switch is used to activate or cancel the auto idle function.
  - Pilot lamp ON : Auto idle function is activated.
  - Pilot lamp OFF : Auto idle function is cancelled.
- ② The buzzer sounds when the machine has a problem.  
In this case, push this switch and buzzer stops, but the warning lamp blinks until the problem is cleared.

### (6) Escape/Camera switch

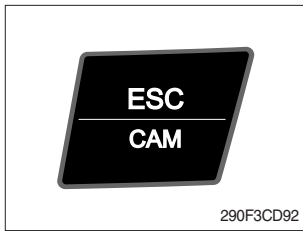

- ① This switch is used to return to the previous menu or parent menu.
- ② In the operation screen, pushing this switch will display the view of the camera on the machine (if equipped). Please refer to page 3-31 for the camera.
- ③ If the camera is not installed, this switch is used only ESC function.

### (7) Work light switch



- ① This switch is used to operate the work light.
- ② The pilot lamp lights up when this switch is pressed.

### (8) Head light switch



- ① This switch is used to operate the head light.
- ② The pilot lamp lights up when this switch is pressed.

### (9) Intermittent wiper switch



- ① This switch is used to wipe operates intermittently.
- ② The pilot lamp lights up when this switch is pressed.

### (10) Wiper switch



- ① This switch is used to operate the wiper.
  - ② Note that the wiper will self-park when switched off.
  - ③ The pilot lamp lights up when this switch is pressed.
- ※ If the wiper does not operate with the switch in ON position, turn the switch OFF immediately. Check the cause. If the switch remains ON, motor failure can result.

### (11) Washer switch

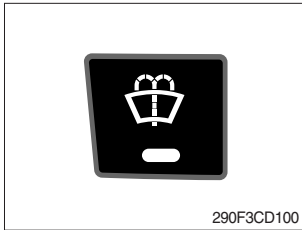

- ① Washer liquid is sprayed and the wiper is operated only when this switch is pressed.
- ② The pilot lamp lights up when this switch is pressed.

### (12) Cab light switch

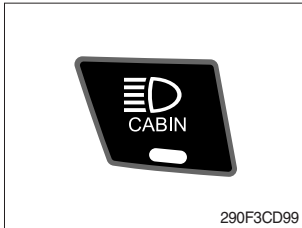

- ① This switch turns on the cab light.
- ② The pilot lamp lights up when this switch is pressed.

### (13) Beacon switch

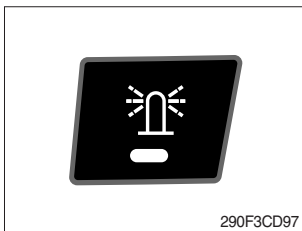

- ① This switch activates the rotary light on the cab.
- ② The pilot lamp lights up when this switch is pressed.

### (14) Overload switch

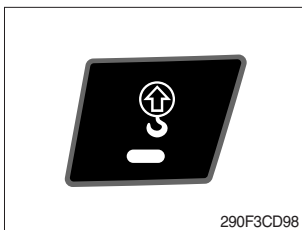

- ① When this switch is activated, buzzer makes sound and overload warning lamp lights up in the event that the machine is or becomes in an overloaded situation.
- ② When the switch is inactivated, buzzer stops and warning lamp goes off.

**⚠ Overloading the machine could impact the machines stability which could result in tipover hazard. A tipover hazard could result in serious injury or death. Always activate the overload warning device before you handle or lift objects.**

### (15) Travel alarm switch

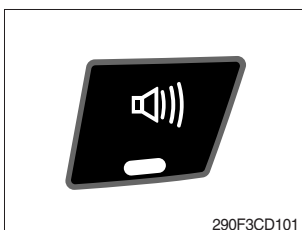

- ① This switch is to activate travel alarm function surrounding when the machine travels.
  - ON : The travel alarm function is activated.
  - OFF : The travel alarm function is not activated.

(16) Main menu quick touch switch



- ① This switch is to activate the main menu in the cluster.
- ※ Refer to the page 3-17.



## 6) MAIN MENU

- ※ On the operation screen, tap MENU to access the main menu screen.  
On the sub menu screen, you can tap the menu bar to access functions or applications.

Normal type

Operation screen

MENU



Tap  
MENU

Main menu screen



Sub menu screen



220S3CD502A

Premium type

Operation screen



Tap  
MENU

Main menu screen





Sub menu screen



220S3CD102A

## (1) Structure

No	Main menu	Sub menu	Description
1	  <p>Mode 220S3CD103</p>	Work mode U mode power Boom/Arm speed Auto power boost IPC mode Auto engine shutdown (opt) Initial mode Emergency mode	Breaker, Crusher, Not installed User mode only Boom speed Enable, Disable Speed mode, Balance mode, Efficiency mode One time, Always, Disable Key on initial mode / initial work mode Switch function
2	  <p>Monitoring 220S3CD104</p>	Active fault Logged fault Delete logged fault Monitoring	MCU, AAVM (opt) MCU, AAVM (opt) All logged fault delete, Initialization canceled Machine information, Switch status, Output status,
3	  <p>Management 220S3CD105</p>	Fuel rate information Maintenance information Machine security Machine information  Contact Service menu  Clinometer Update	General record, Hourly, Daily, Mode record Replacement, Change interval oils and filters ESL mode setting, Password change Model, MCU, Monitor RMCU, Relay drive unit, AAVM (opt) A/S phone number, A/S phone number change Power shift, Operating hour, Breaker mode pump acting, EPPR current level, Overload pressure Clinometer setting Cluster, ETC device
4	  <p>Display 220S3CD106</p>	Display item Clock Brightness Unit setup Language selection Screen type★	Engine speed, Tripmeter A, Tripmeter B, Tripmeter C Clock Manual, Auto Temperature, Pressure, Flow, Distance, Date format Korean, English, ETC A type, B type
5	  <p>Utilities 220S3CD107</p>	Tripmeter Camera setting AUX Manual	3 kinds (A, B, C) Number of active, Display order, AAVM (opt)★

★ : premium type

## (2) Mode setup

※ Illustrations are based on the premium type cluster.

### ① Work mode

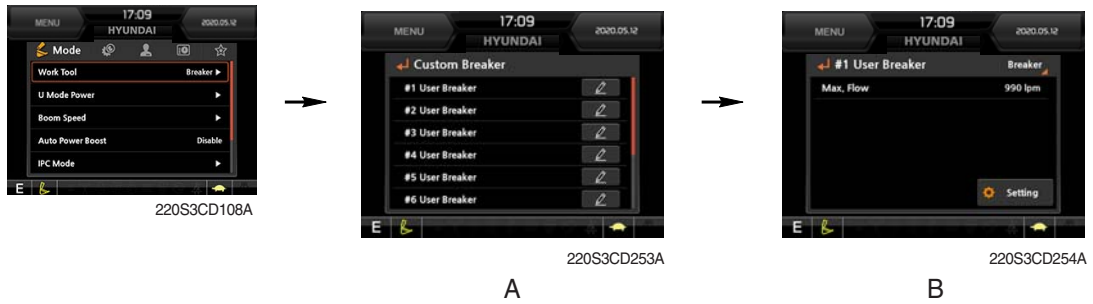

- Select installed optional attachment
  - A : It can set the user's attachment.  
It is available in setting #1~#10.
  - B : Max flow - Set the maximum flow for the attachment.

### ② U mode power

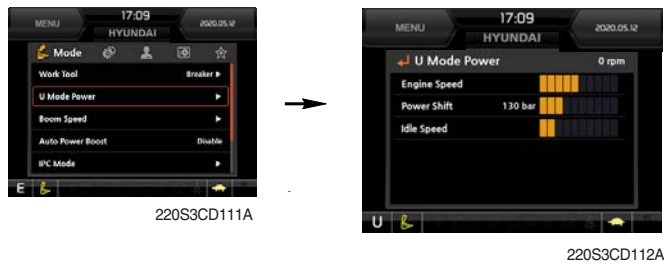

Step (■)	Engine speed (rpm)	Idle speed (rpm)	Power shift (bar)
1	1550	1000	0
2	1600	1050	3
3	1650	1100	6
4	1700	1150 (auto decel)	9
5	1750	1200	12
6	1800	1250	16
7	1850	1300	20
8	1900	1350	26
9	1950	1400	32
10	2000	1450	38

- Engine high idle rpm, auto idle rpm and pump torque (power shift) can be modulated and memorized separately in U-mode.
- U-mode can be activated by user mode switch.

※ One touch decel & low idle : 1000 rpm

### ③ Boom speed

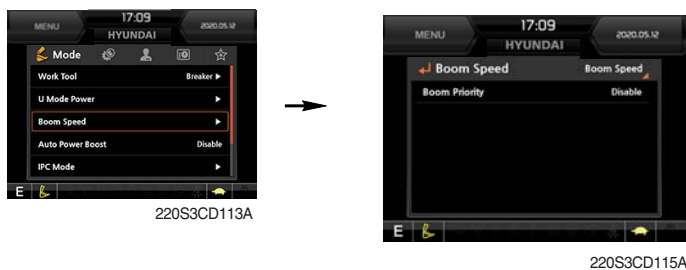

- Boom speed
  - Boom priority function can be activated or cancelled
  - Enable - Boom up speed is automatically adjusted as working conditions by the MCU.
  - Disable - Normal operation

#### ④ Auto power boost



- The power boost function can be activated or cancelled.
  - Enable - The digging power is automatically increased as working conditions by the MCU. It is operated max 8 seconds, then goes off for a period of 1 second and then activates again for 8 seconds and continues this cycle.
  - Disable - Not operated.

#### ⑤ IPC mode

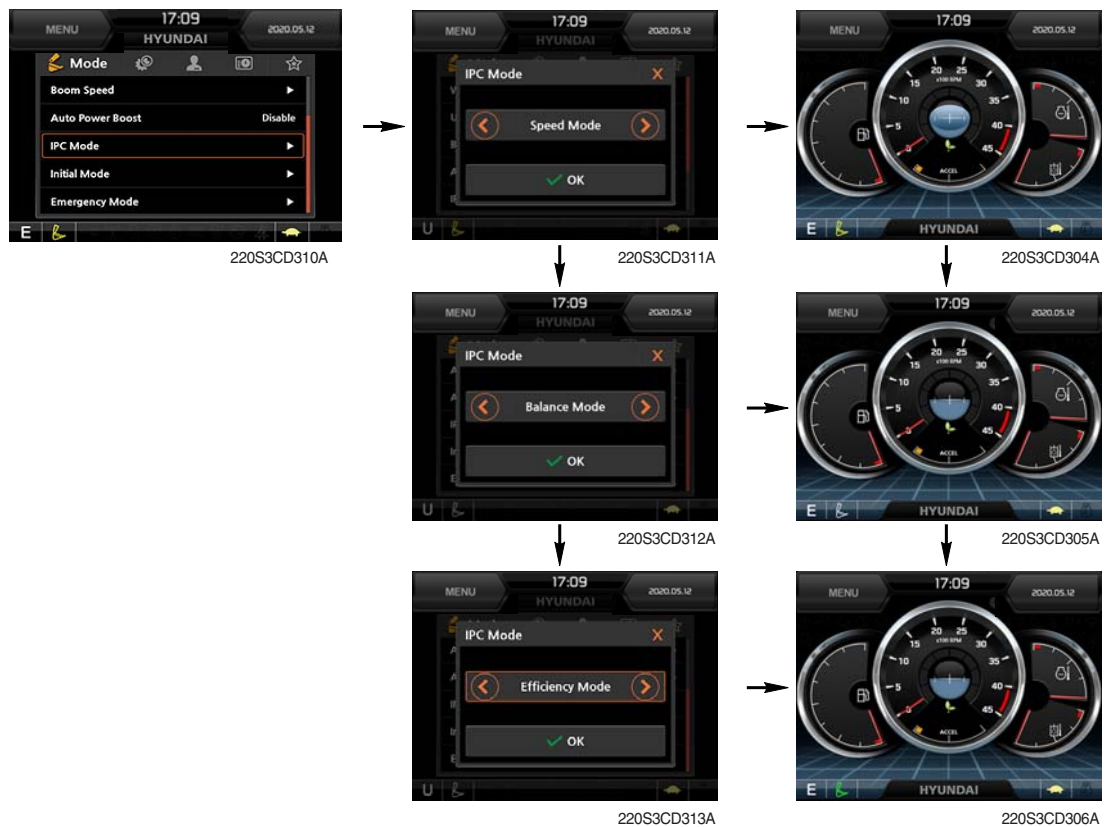

- The IPC mode can be selected by this menu.
  - Speed mode
  - Balance mode (default)
  - Efficiency mode

### ⑥ Automatic engine shutdown (option)



- The automatic engine shutdown function can be set by this menu.
  - One time
  - Always
  - Disable
  - Wait time setting : Max 40 minutes, min 2 minutes

### ⑦ Initial mode



- **Key on initial mode**
  - Selected the power mode is activated when the engine is started.

#### Key on initial work mode

- Not installed
- Last setting
- Work mode

### ⑧ Emergency mode



- This mode can be used when the switches are abnormal on the cluster.
- The cluster switches can be selected by touching each icon.

### (3) Monitoring

#### ① Active fault

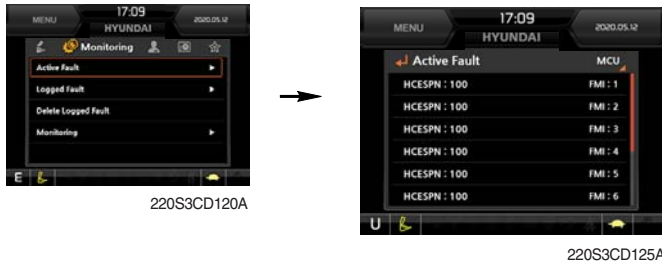

- The active faults of the MCU can be checked by this menu.

#### ② Logged fault

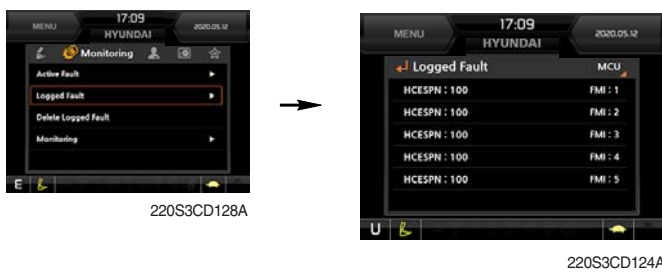

- The logged faults of the MCU can be checked by this menu.

#### ③ Delete logged fault



- The logged faults of the MCU can be deleted by this menu.

#### ④ Monitoring



- The machine status such as the engine rpm, oil temperature, voltage and pressure etc. can be checked by this menu (Analog input).
- The switch status or output status can be confirmed by this menu (Digital input & Digital output).
- The activated switch or output pilot lamps ● will light up.

#### (4) Management

##### ① Fuel rate information



220S3CD14A



220S3CD15A

A



220S3CD16A

B



220S3CD17A

C



220S3CD18A

D



220S3CD19A

- **General record (A)**

- Average fuel rate (left) (from "Reset" to now)  
Fuel consumption divided by engine run time (service meter time).
- A days fuel used (right)  
Fuel consumption from 24:00 (or "Reset" time) to now (MCU real time).

- **Hourly record (B)**

- Hourly fuel rates for past 12 hours (service meter time).
- No record during key-off time.
- One step shift to the right for every one hour.
- Automatic deletion of data from 12 hours and earlier.
- "Reset" deletes all hourly records.

- **Daily record (C)**

- Daily fuel consumption for past seven days (MCU real time).
- No record during key-off time.
- One step shift to the right at 24:00 for every day.
- Automatically deletes data from 7 days and earlier.
- All daily records deletion by "Reset".

- **Mode record (D)**

- Average fuel rate for each power mode/accl dial (at least 7) from "Reset" till present.
- No record during idle.
- All records can be deleted by "Reset".

## ② Maintenance information



220S3CD131A



220S3CD132A



220S3CD133A

- Alarm lamp ( ● ) is ON when oil or filter needs to be changed or replaced.
  - Replacement : The elapsed time will be reset to zero (0).
  - Change interval : The change intervals can be changed in hour increments of 50.
- ※ Refer to section, Maintenance chart for further information of maintenance interval.



### ③ Machine security



#### · ESL mode setting

- ESL : Engine Starting Limit
- ESL mode is designed to be a theft deterrent or will prevent the unauthorized operation of the machine.
- When you Enable the ESL mode, the password will be required when the starting switch is turned to the on position.

#### - Machine security

Disable : ESL function is disabled and password is not required to start engine.

Enable (always) : The password is required whenever the operator starts engine.

- Interval : The password is required when the operator starts engine first. But the operator can restart the engine within the interval time without inputting the password. The interval time can be set to a maximum 4 hours.

※ Default password : 00000 + ✓

※ Password length : (5~10 digits) + ✓

- Smart key (option) : Refer to next page.

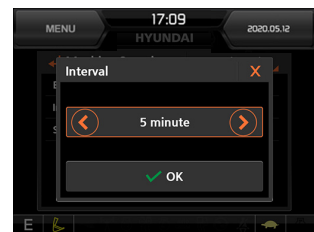

#### · Password change

- The password is 5~10 digits.



Enter the current password



Enter the new password again



Enter the new password

※ Before first use, please set user password and owner password in advance for machine security.

## - Smart key



220S3CD190A



220S3CD135A

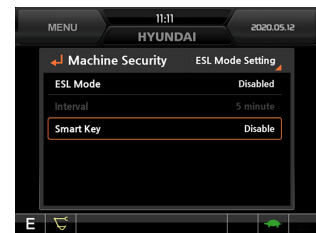

235F3CD001

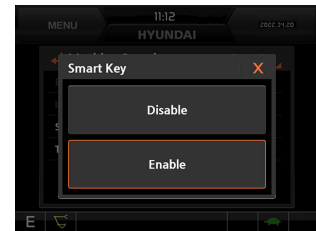

235F3CD002

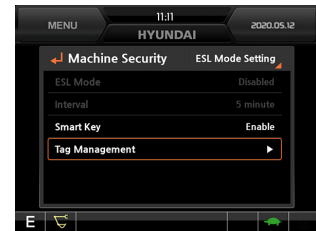

235F3CD003

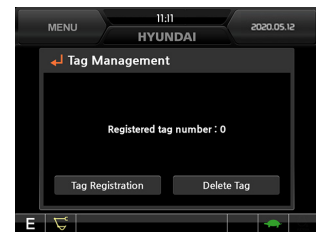

235F3CD004

Registering

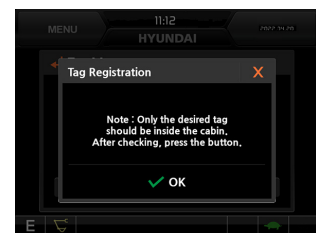

235F3CD005

- Smart key is registered when equipped with optional smart key. If smart key is not inside of the cabin, authentication process fails and the password is needed.
- Tag management menu is activated when the Smart key menu is Enabled.  
You can register and delete the tags.

## - Tag management

- When registering a tag : Only the tag you want to register must be in the cabin.
- When deleting a tag : All registered tags are deleted.

Deleting

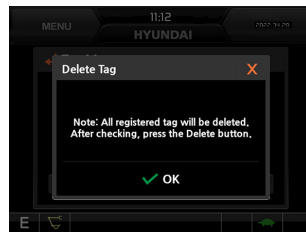

235F3CD006

## ※ Engine Starting Condition

Case	ESL Mode	Smart Key	Condition
1	Disable	Disable	- With registered tag : Engine can be started without password input. - Without registered tag : Engine can be started without password input.
2	Disable	Enable	If Smart Key is enabled, ESL Mode is automatically enabled. This Case 2 work the same as the Case 4.
3	Enable	Disable	- With registered tag : Engine can be started with password input. - Without registered tag : Engine can be started with password input.
4	Enable	Enable	- With registered tag : Engine can be started without password input. - Without registered tag : Engine can be started with password input.

#### ④ Machine Information

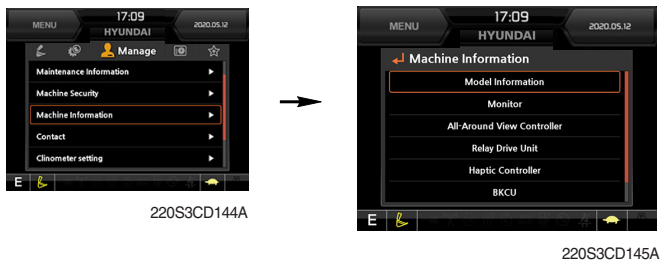

- This can confirm the identification of the model information (ECU), MCU, monitor, switch controller, RMCU, relay driver unit, AAVM (opt).

#### ⑤ Contact (A/S phone number)



Enter the new A/S phone number

#### ⑥ Service menu



※ This menu can be used only HCE service man and can not be accessible by the owner and the operator.

- Power shift (standard/option) : Power shift pressure can be set by option menu.
- Operating hours : Operating hours since the machine line out can be checked by this menu.
- Breaker mode pump acting (null)
- EPPR current level (attach flow EPPR 1 & 2)
- Overload pressure : 100 ~ 350 bar

#### ⑦ Clinometer

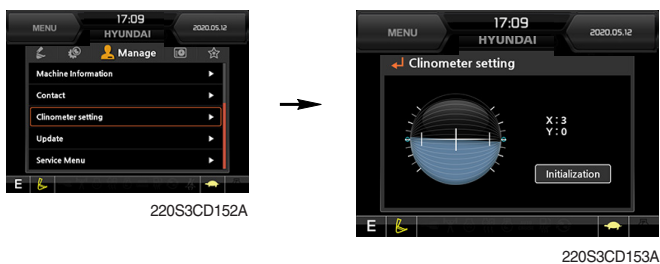

- When the machine is on the flatland, if you touch "initialization" on cluster, the values of X, Y will reset to "0".
- You can confirm tilt of machine in cluster's operating screen.

⑧ Update (cluster & ETC devices)

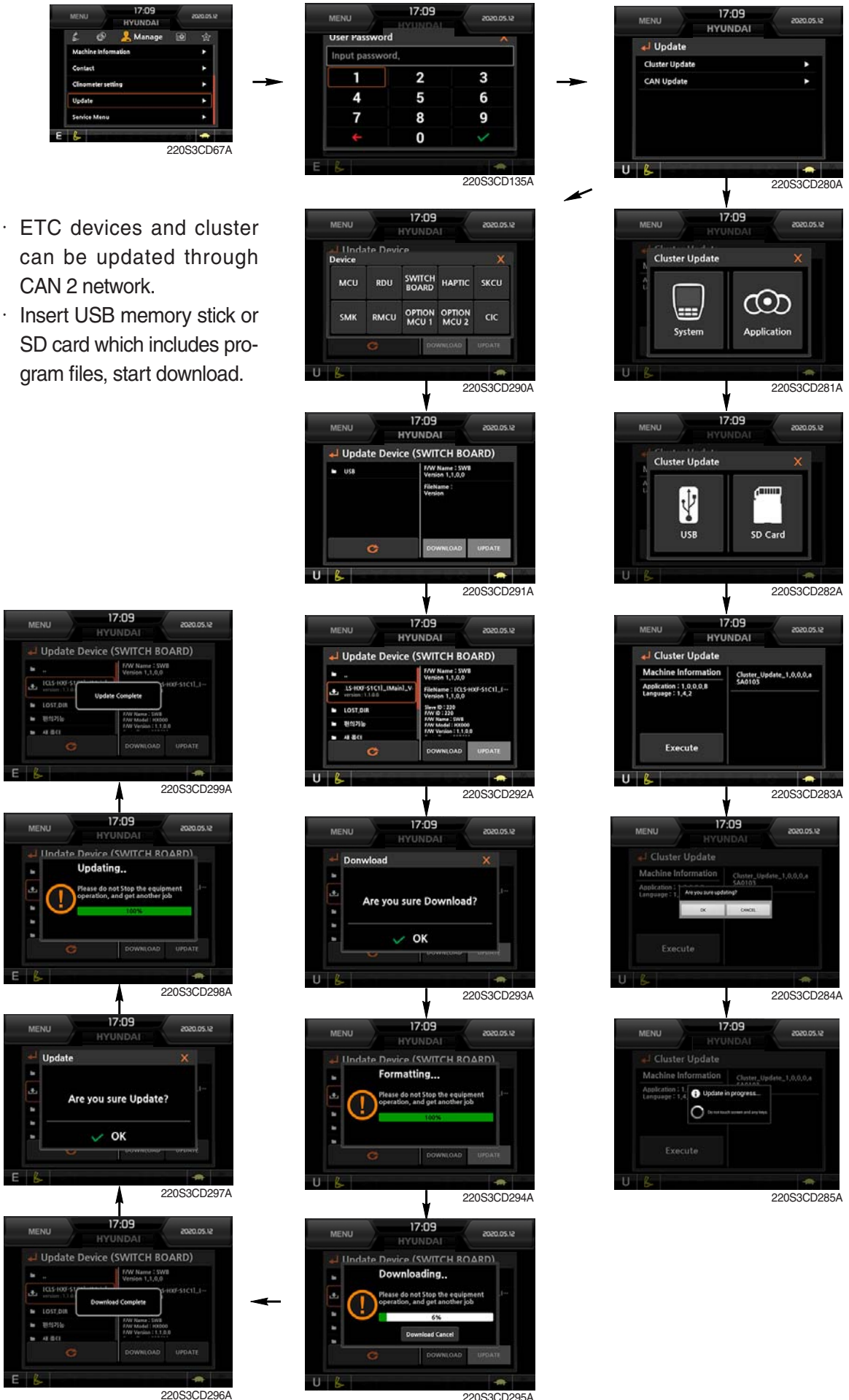

- ETC devices and cluster can be updated through CAN 2 network.
- Insert USB memory stick or SD card which includes program files, start download.

## (5) Display

### ① Display item



220S3CD154A



220S3CD155A



220S3CD156A

- The center display type of the LCD can be selected by this menu.
- The engine speed or the tripmeter menu (A,B,C) is displayed on the center display.

### ② Clock



220S3CD157A



220S3CD158A

- The first row of boxes indicate Year/Month/Day.
- The second row shows the current time. (0:00~23:59)

### ③ Brightness



220S3CD159A



220S3CD160A



220S3CD139A



220S3CD141A



220S3CD191A



220S3CD192A

- If "Auto" is chosen, brightness for day and night can be set accordingly. Also by using the bar in lower side, users can define which an operation interval belongs to day and night. (in bar figure, white area represents night time while orange shows day time)

#### ④ Unit

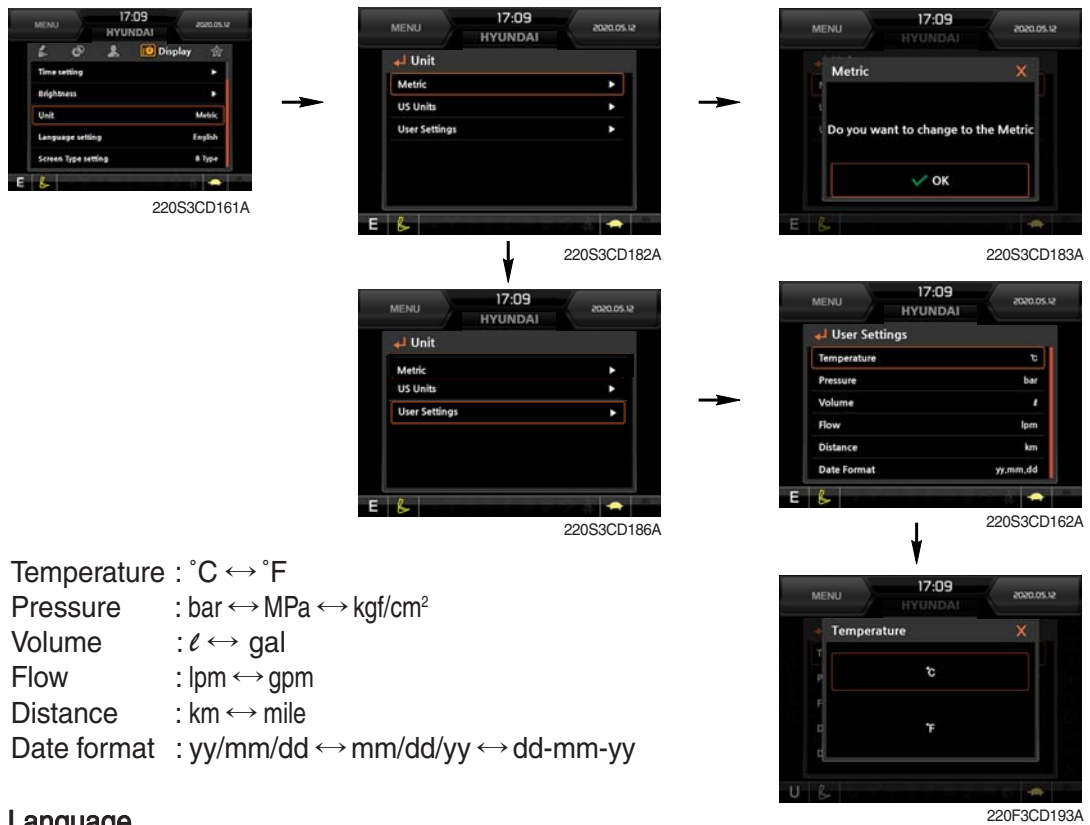

- Temperature : °C ↔ °F
- Pressure : bar ↔ MPa ↔ kgf/cm<sup>2</sup>
- Volume : ℓ ↔ gal
- Flow : lpm ↔ gpm
- Distance : km ↔ mile
- Date format : yy/mm/dd ↔ mm/dd/yy ↔ dd-mm-yy

#### ⑤ Language



- User can select preferable language and all displays are changed to the selected language.

⑥ Screen type (premium type)



220S3CD165A



A Type (Default) 220S3CD166A



220S3CD156A



B Type (Option) 220S3CD174A



220S3CD167A

## (6) Utilities

### ① Tripmeter



220S3CD168A



220S3CD169A

- A maximum of 3 kinds of tripmeters can be used at the same time.
- Each tripmeter can be turned on by choosing "Start". It also can be turned off by choosing "Stop".
- If the tripmeter icon is activated in the operation screen, it can be controlled directly there.

### ② Camera setting

- If the rear camera is not installed on the machine, set disable.
- If the rear camera is installed on the machine, set enable.



220S3CD225A



220S3CD255A



220S3CD256A

- In the operation screen, rear camera screen shows up when ESC/CAM switch is pushed.



220S3CD222A



290F3CD221



### ③ AAVM (Advanced Around View Monitoring, premium type, opt)

- The AAVM switches of the cluster consist of ESC/CAM and AUTO IDLE/Buzzer stop.



220S3CD244A

#### - Escape switch

- Activates AAVM mode from the beginning if AAVM is installed.
- While in the AAVM mode, select the ESC switch to return to the home screen.



220S3CD156A

Home screen

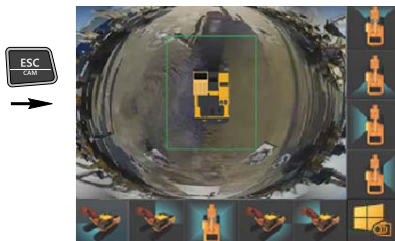

AAVM mode

235SA3CD222A

#### - Buzzer stop switch

- AAVM mode detects surrounding pedestrians or objects and the warning buzzer sounds.
- User can turn OFF the warning sound by pressing buzzer stop switch.



290F3CD246A

- When a worker/pedestrian reaches the green line, which is an external danger area equipped on the cluster, warning buzzer sounds and it displays a green rectangular box recognizing the worker/pedestrian. Stop work immediately. Stop the buzzer by pressing the buzzer stop switch. Then resume work after you confirm that the area is safe and clear of workers/objects.



290F3CD247A

- When a worker/pedestrian reaches the red line, which is an external danger area equipped on the cluster, warning buzzer sounds and it displays a red rectangular box recognizing the worker/pedestrian. Stop work immediately. Stop the buzzer by pressing the buzzer stop switch. Then resume work after you confirm that the area is safe and clear of workers/objects.

**▲ Failure to comply may result in serious injury or death.**

**※ In AAVM mode, a touch screen of the LCD is available only.**

### 3. SWITCHES

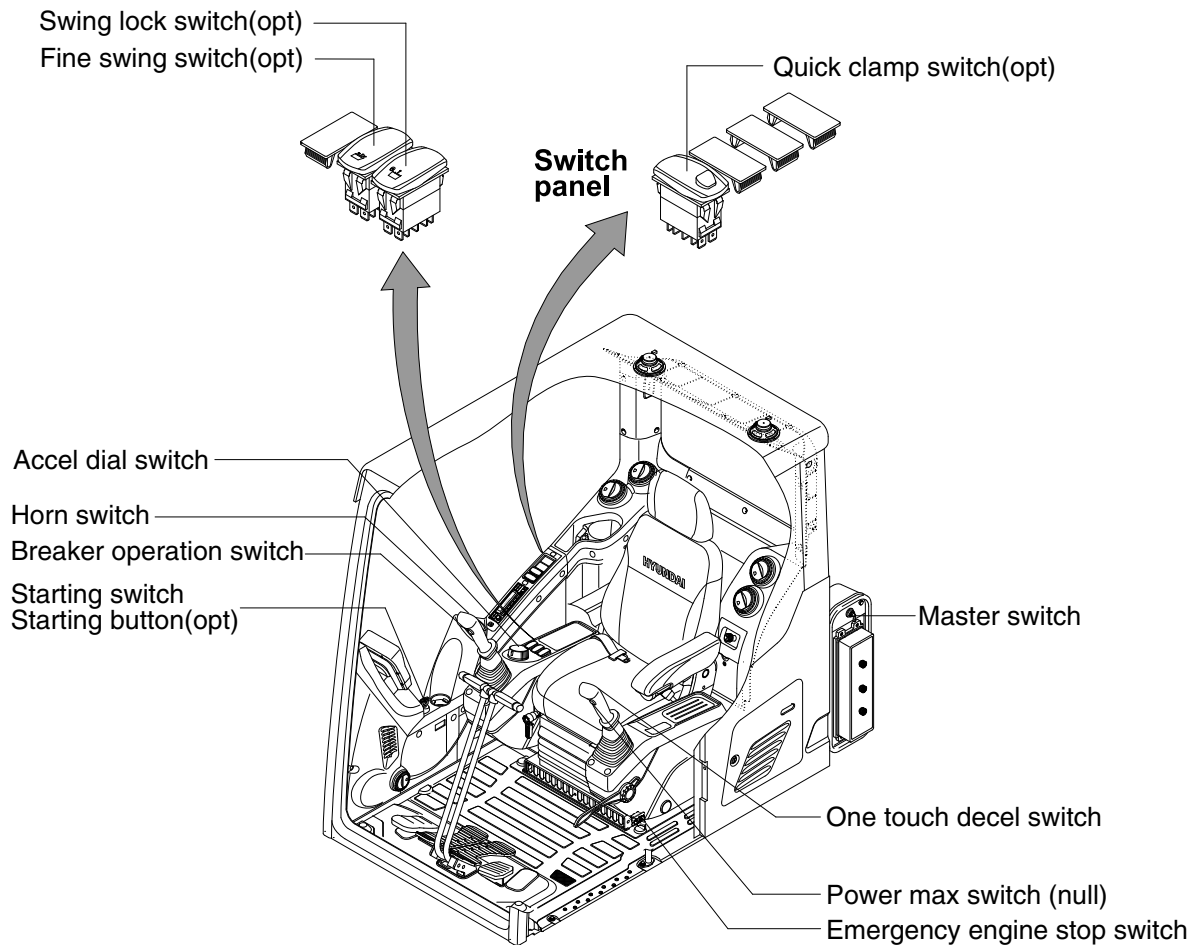

140SA3CD32

#### 1) STARTING SWITCH & STARTING BUTTON (OPT)

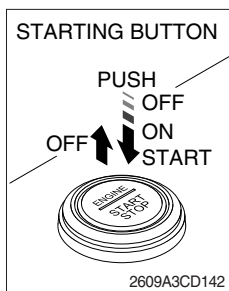
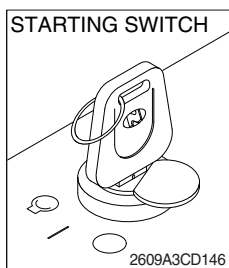

Starting button with smart key tag (opt)

(1) There are three positions, OFF, ON and START.

- ○ (OFF) : No of electrical circuits activate.
- | (ON) : All the systems of machine operate.
- ○ (START) : Use when starting the engine.

Release key immediately after starting.

- ※ If you turn ON the starting switch in cold weather, the fuel warmer is automatically operated to heat the fuel by sensing the coolant temperature. Start the engine in 1~2 minutes after turning ON the starting switch. More time may be required according to ambient temperature.
- ※ Starting switch controller tries engine starting at least 3 seconds even if switch is released after driver's start trial (key switch : start position / starting button : long push) to prevent short-time cranking (which can not starting engine). If no-start conditions (unlock safety knob) are resolved (lock safety knob) during the 3 seconds of engine starting attempt, engine can be started.
- ※ Key must be in the ON position with engine running to maintain electrical and hydraulic function and prevent serious machine damage.

## 2) MASTER SWITCH

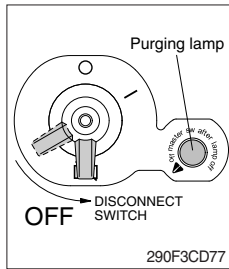

- (1) This switch is used to shut off the entire electrical system.
  - (2) I : The battery remains connected to the electrical system.  
O : The battery is disconnected from the electrical system.
- ※ **Never turn the master switch to O (OFF) with the engine running. Engine and electrical system damage could result.**
  - ※ **Turn OFF the master switch after purging lamp goes OFF.**

## 3) ACCEL DIAL SWITCH

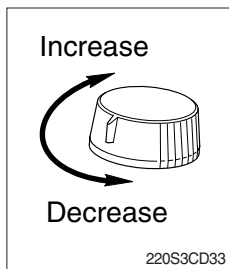

- (1) There are 10 dial setting.
- (2) Setting 1 is low idle and setting 10 is high idle.
  - By rotating the accel dial to right : Engine speed increases.
  - By rotating the accel dial to left : Engine speed decreases.

## 4) QUICK CLAMP SWITCH (option)

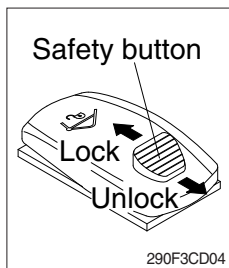

- (1) This switch is used to engage or disengage the moving hook on quick clamp.
- ※ **Refer to the page 8-6 for details.**

## 5) AIR COMPRESSOR SWITCH (option)

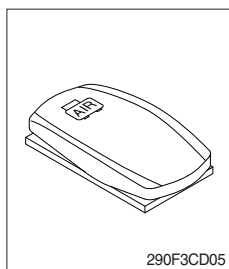

- (1) This switch is used to activate the air compressor.
- (2) The pilot lamp lights up when this switch is activated.

## 6) SWING LOCK SWITCH (option)

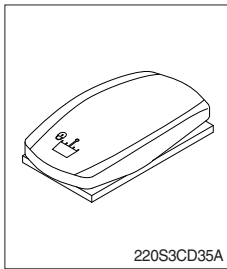

- (1) This switch is used to lock the swing parking brake.
- (2) Swing control is not available when this switch is activated.

## 7) FINE SWING SWITCH (option)

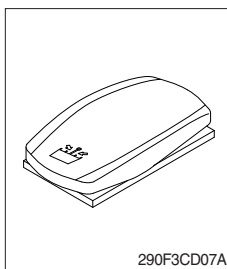

- (1) When the switch is pressed to the ON position, the swing parking brake is released.
  - (2) Swing control improves during deceleration of a swing because the swing is allowed the drift instead of stopping abruptly.
- ▲ If the machine is operating on a slope with the switch in the ON position, swing motion may become uncontrollable which could result in property damage, serious injury or death. Do not select ON position when the machine is operating on a slope.**

## 8) EMERGENCY ENGINE STOP SWITCH

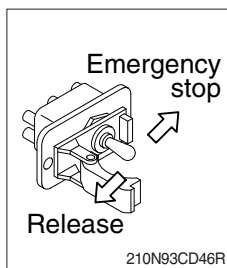

- (1) This switch is used to stop the engine in the event of an emergency.
- ※ Be sure to return the emergency switch to the release or run position before trying to restart the engine.**

## 9) LH RCV LEVER SWITCH

### (1) Button type

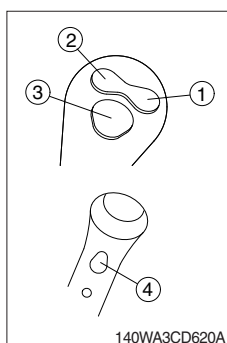

The switches on the LH RCV lever is function as below.

- ① None
  - ② None
  - ③ **One touch decel switch**
    - a. This switch is used to actuate the deceleration function quickly.
    - b. The engine speed is increased to previous setting value by pressing the switch again or operating state (working/travel).
  - ④ **Power max switch**
    - a. This switch activates power max function.  
When this switch is pressed and held, hydraulic power of work equipment will be increased to approx 110 percent for a period of 8 seconds.
    - b. After 8 seconds, function is cancelled automatically even if the switch remains pressed.
- ※ Do not use for craning purposes.**

## (2) Proportional type (option)

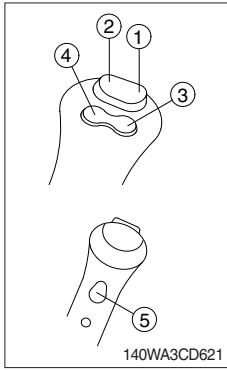

The switches on the LH RCV lever is function as below.

### ① CW rotating switch

When this switch is pressed, the clockwise rotating will operate.

### ② CCW rotating switch

When this switch is pressed, the counterclockwise rotating will operate.

### ③ One touch decel switch : Refer to (1)-③ above.

### ④ None.

### ⑤ Power max switch : Refer to (1)-④ above.

## 10) RH RCV LEVER SWITCH

### (1) Button type

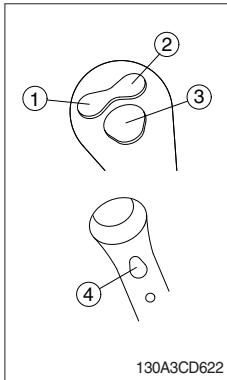

The switches on the RH RCV lever is function as below.

### ① None

### ② None

### ③ Horn switch

When this switch is pressed, the horn will sound.

### ④ Breaker switch

When this switch is pressed, the breaker will only operate when the breaker operation mode is selected.

### (2) Proportional type (option)

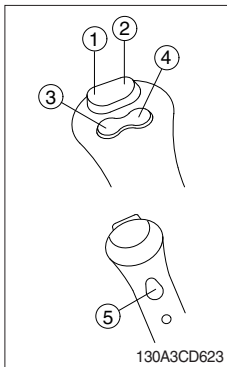

The switches on the RH RCV lever is function as below.

### ① 2-way clamp switch

When this switch is pressed, the clamp will only operate when the crusher operation mode is selected.

### ② 2-way release switch

When this switch is pressed, the release or breaker will operate when the crusher operation mode or breaker operation mode is selected.

### ③ Quick clamp switch

This switch is used to engage or disengage the moving hook on quick clamp.

**Refer to the page 8-6.**

### ④ Horn switch : Refer to (1)-③ previous page.

### ⑤ Breaker switch : Refer to (1)-④ previous page.

## 4. LEVERS AND PEDALS

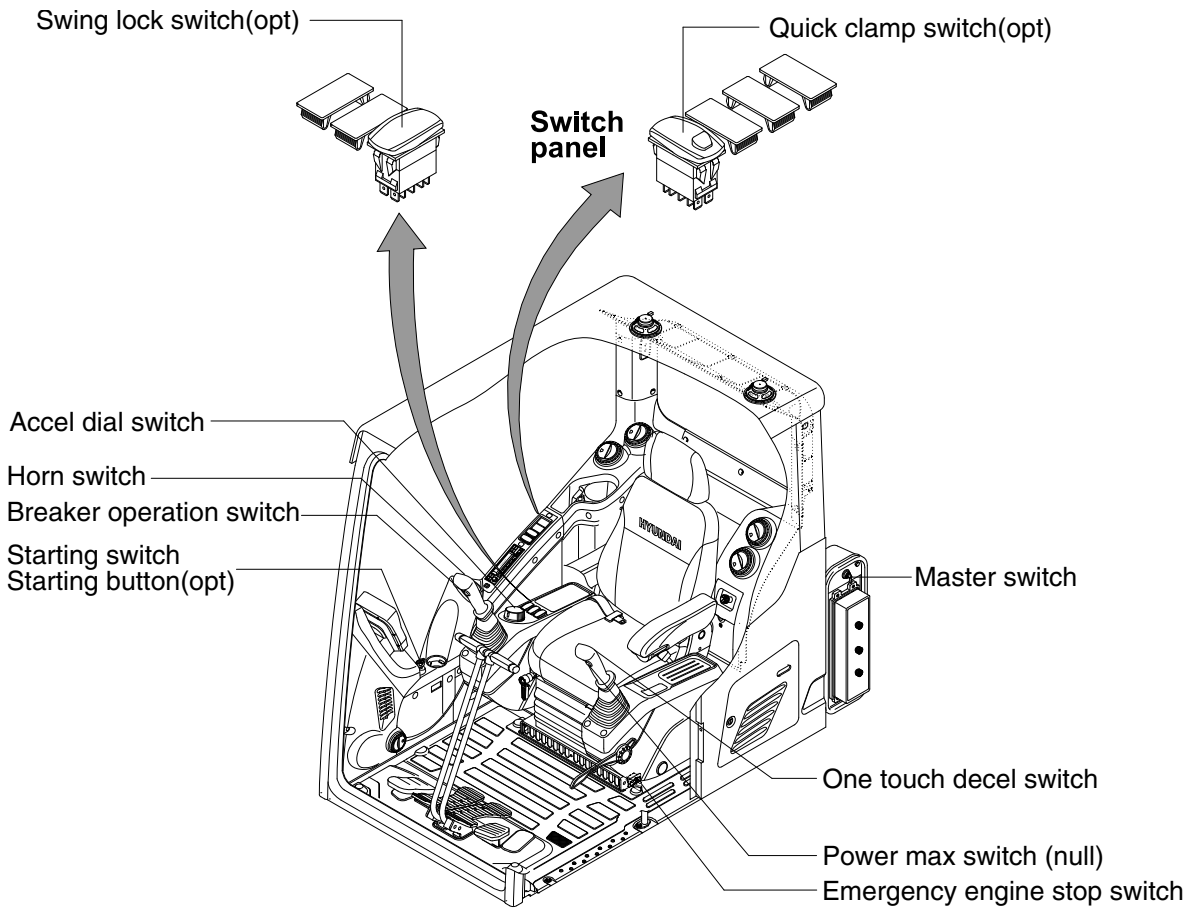

140SA3CD32

### 1) LH CONTROL LEVER

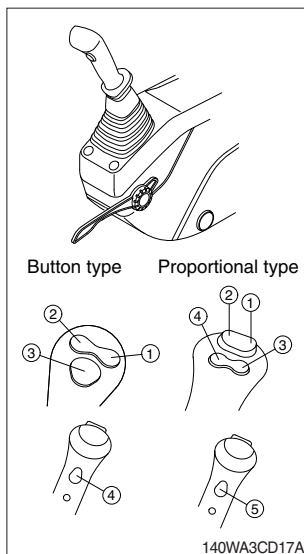

(1) This joystick is used to control the swing and the arm.

※ Refer to operation of working device in chapter 2 for details.

(2) The switch functions are as below.

No.	Button type	Proportional type (opt)
①	N.A	Rotating-CW
②	N.A	Rotating-CCW
③	One touch decel	One touch decel
④	Power max	N.A
⑤	-	Power max

※ Refer to page 3-35 for the details of the switch function.

## 2) RH CONTROL LEVER

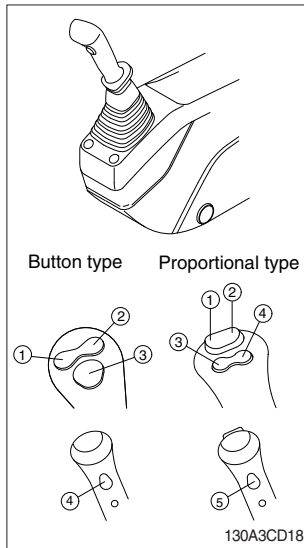

(1) This joystick is used to control the boom and the bucket.  
 ※ Refer to operation of working device in chapter 2 for details.

(2) The switch functions are as below.

No.	Button type	Proportional type (opt)
①	N.A	2-way clamp
②	N.A	2-way release
③	Horn	N.A
④	Breaker	Horn
⑤	-	Breaker

※ Refer to page 3-36 for the details of the switch function.

## 3) SAFETY KNOB

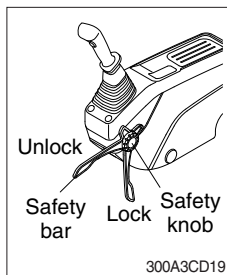

(1) All control levers and pedals are disabled from operation by locating the safety knob to the LOCK position as shown.

※ Be sure to turn the safety knob to the LOCK position when entering or leaving the operators seat/cabin.

(2) The machine is operational by turning the safety knob to the UNLOCK position.

※ Do not use the safety bar for a handle when getting on or off the machine.

## 4) TRAVEL LEVER

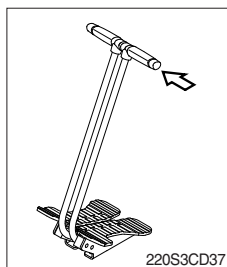

(1) This lever is mounted on travel pedal and used for traveling by hand. The operation principle is same as the travel pedal.

(2) Refer to traveling of the machine in chapter 2 for details.

## 5) TRAVEL PEDAL

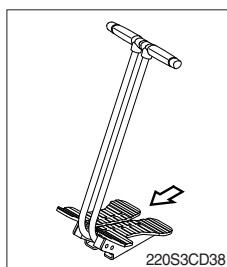

(1) This pedal is used to move the machine forward or backward.

(2) If left side pedal is pressed, left track will move.  
 If right side pedal is pressed, right track will move.

(3) Refer to traveling of machine in chapter 2 for details.

## 6) SEAT AND CONSOLE BOX ADJUST KNOB (forward/backward)

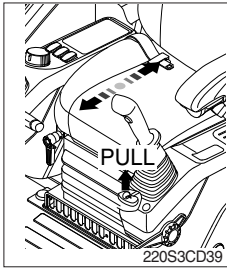

- (1) This knob is used to move the seat and console box to fit the contours of the operator's body.
- (2) Pull the knob to adjust forward or backward over 150 mm (5.9").

## 7) CONSOLE BOX (CONTROL LEVER) HEIGHT ADJUST KNOB

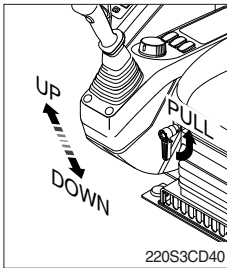

- (1) This knob is used to move the LH and RH control levers to fit the contours of the operator's body.
- (2) The control levers can be moved upward and downward at 45° over 80 mm (2.4").



## 5. AIR CONDITIONER AND HEATER

Full auto air conditioner and heater system automatically keeps the optimum condition in accordance with operator's temperature configuration, sensing ambient and cabin inside temperature.

### · Location of air flow ducts

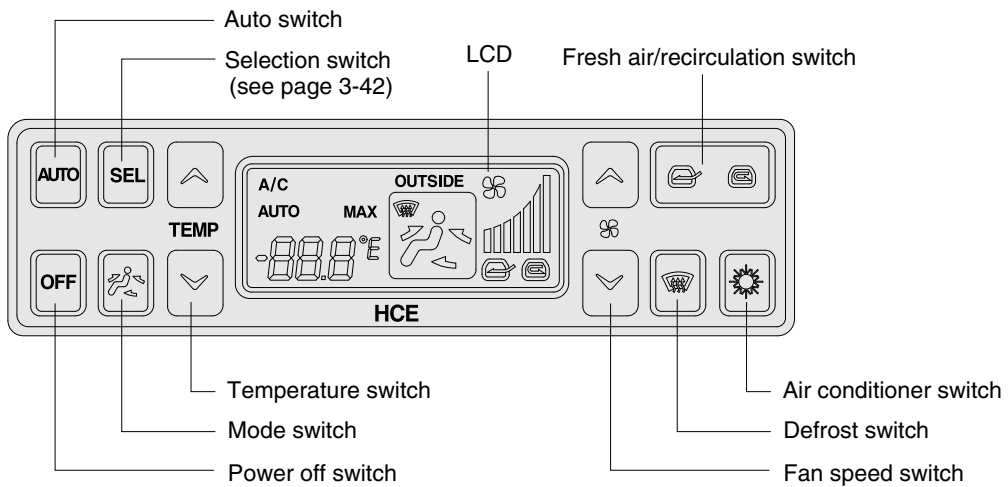
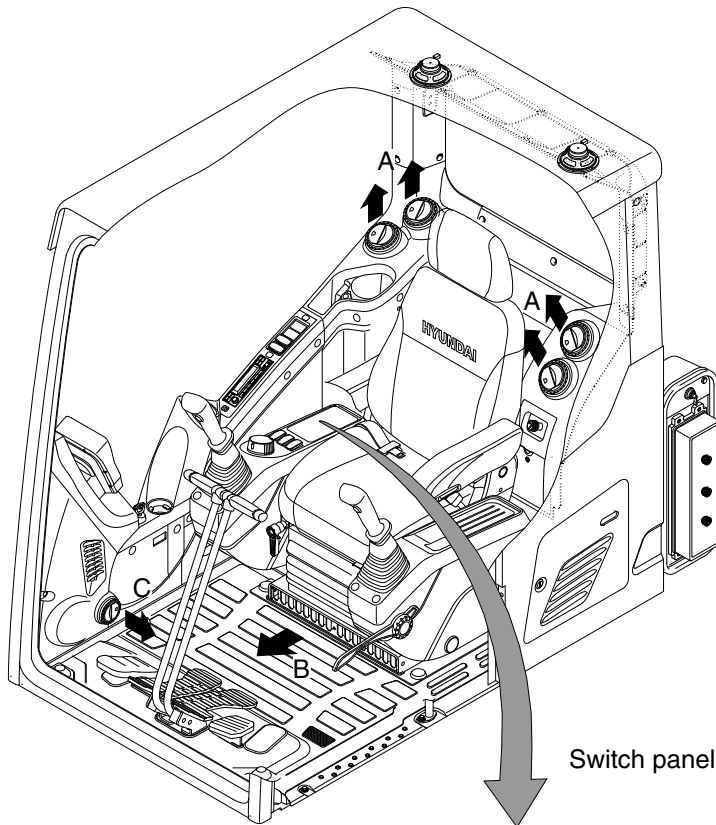

220S3CD49

### 1) POWER OFF SWITCH

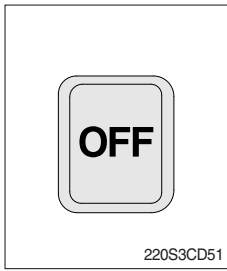

- (1) This switch turns the system ON and OFF.  
Just before powering OFF, set values are stored.

#### (2) Default setting values

Function	Air conditioner	In/outlet	LCD	Temperature	Mode
Value	OFF	Inlet	OFF	Previous sw OFF	Previous sw OFF

### 2) AUTO SWITCH

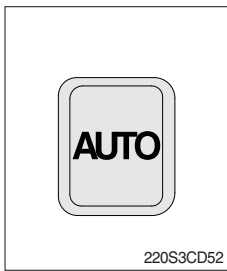

- (1) Turn the starting switch to ON position, LCD lights ON.  
Auto air conditioner and heater system automatically keeps the optimum condition in accordance with operator's temperature configuration sensing ambient and cabin inside temperature.
- (2) This switch can restart system after system OFF.

### 3) AIR CONDITIONER SWITCH

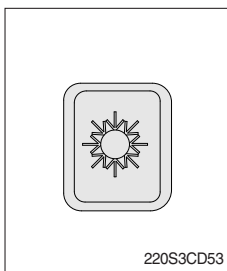

- (1) This switch turns the compressor ON/OFF.
- (2) In accordance with the temperature sensed by duct (evaporator) sensor, compressor turns ON or OFF automatically.
- ※ **Air conditioner operates to remove vapor and drains water through a drain hose. Water can be sprayed into the cab in case that the drain cock at the ending point of drain hose has a problem. In this case, exchange the drain cock.**

### 4) FAN SPEED SWITCH

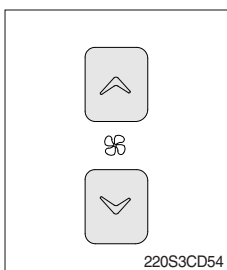

- (1) Fan speed is controlled automatically by set temperature.
- (2) This switch controls fan speed manually.
- There are 5 steps (OFF, 1 ~ 4 speed) to control fan speed.
  - The maximum step or the minimum step beeps 5 times.
- (3) This switch makes the system ON.

## 5) TEMPERATURE CONTROL SWITCH

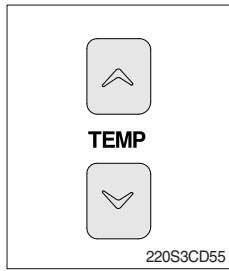

- (1) Setting temperature indication (17~32°C, scale : 0.5°C)
- (2) Max cool and max warm beeps 5 times.
- (3) The max cool or the max warm position operates as following table.

Temperature	Compressor	Fan speed	In/Outlet	Mode
Max cool	ON	Max (Hi)	Recirculation	Vent
Max warm	OFF	Auto (Hi)	Fresh	Foot

- (4) Temperature unit can be changed between celsius (°C) and fahrenheit (°F)
  - ① Default status (°C)
  - ② Push Up/Down temperature control switch simultaneously more than 5 second displayed temperature unit change (°C → °F)

## 6) MODE SWITCH



- (1) Operating this switch, it beeps and displays symbol of each mode in the following order. (Vent → B/L → Foot → Mix → Vent)

Mode switch		Vent	B/L	Foot	Mix
Outlet	A	●	●		
	B		●	●	●
	C				●

## 7) FRESH AIR/RECIRCULATION SWITCH

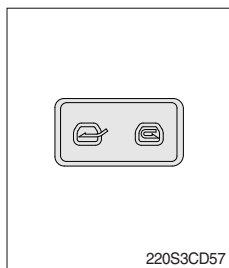

- (1) It is possible to change the air-inlet method.
  - ① **Fresh air** ( )  
Inhaling air from the outside.  
※ **Check out the fresh air filter periodically to keep a good efficiency.**
  - ② **Air recirculation** ( )  
It recycles the heated or cooled air to increase the energy efficiency.  
※ **Change air occasionally when using recirculation for a long periods of time.**  
※ **Check condition of fresh air filter and recirculation filter periodically to maintain good efficiency of the system.**

## 8) DEFROST SWITCH

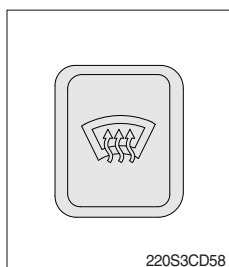

- (1) This switch makes the defrost mode operating.
- (2) When defroster mode operating, fresh air/recirculation switch turns to fresh air mode and air conditioner switch turns ON.

## 9) SELF DIAGNOSIS FUNCTION

### (1) Procedure

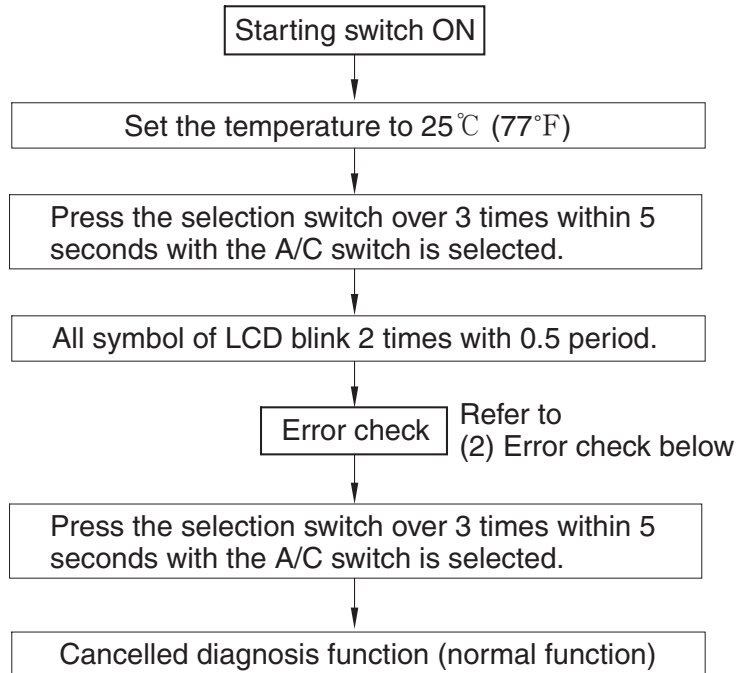

220S3CD59

### (2) Error check

- If normal, display E0.
- The corresponding error code flickers on the setup temperature display panel, the other symbol will turn OFF.
- Error code flickers every 0.5 second.
- If error code is more than two, each code flickers 2 times in sequence.
- Up and down the error codes by pressing the temperature control switch.
- Error code

Error code	Description	Error code	Description
E0	Normal	E5	Duct sensor short
E1	Incar sensor short	E6	Duct sensor open
E2	Incar sensor open	E11	DPS open
E3	Ambient sensor short	E12	Mode actuator fail
E4	Ambient sensor open	E13	Mix actuator fail

## 6. OTHERS

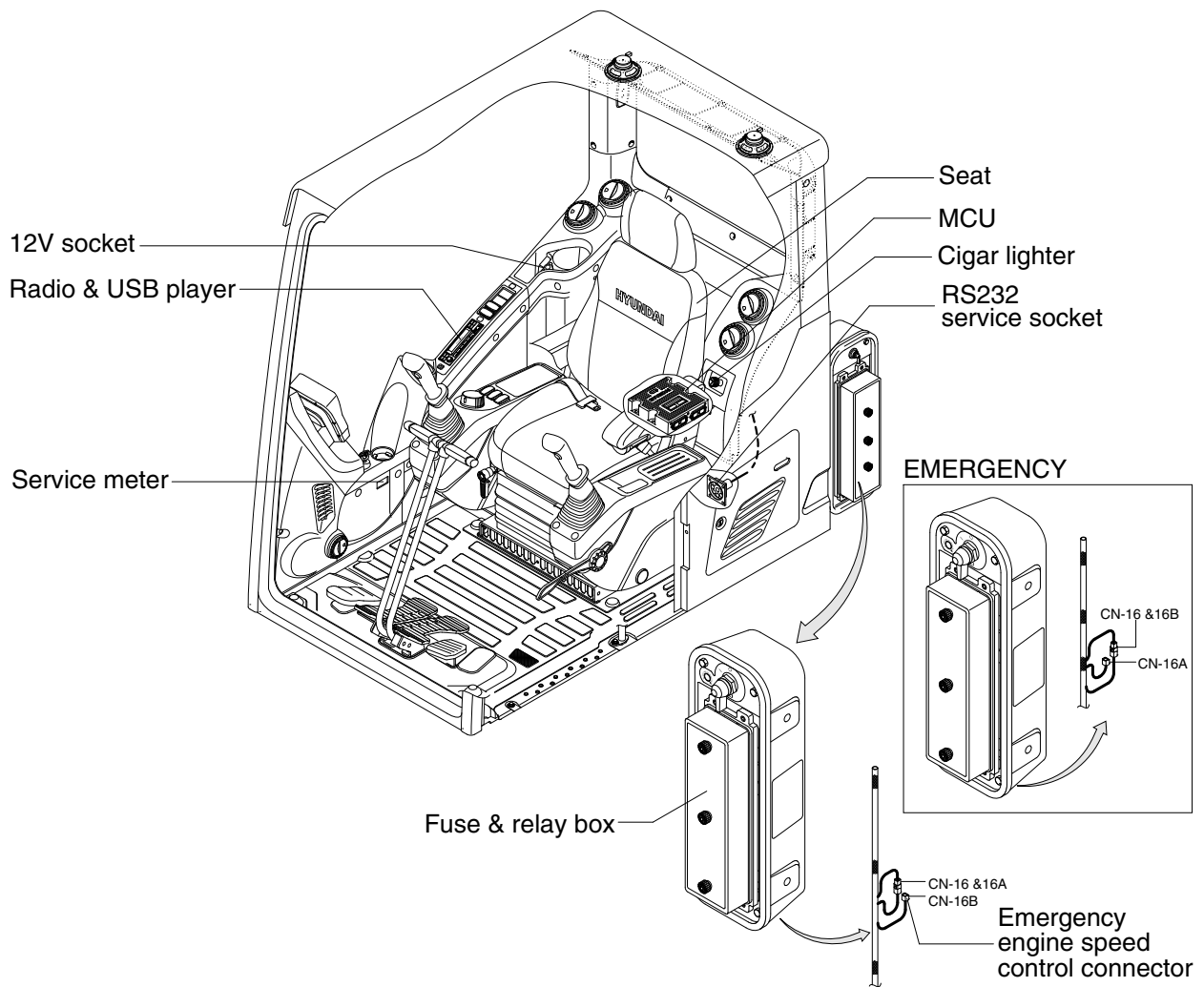

220SA3CD41

### 1) CIGAR LIGHTER

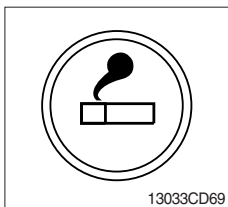

- (1) This can be used when the engine starting switch is ON.
- (2) The lighter can be used when it springs out in a short while after being pressed down.

※ **Service socket**

**Use cigar lighter socket when you need emergency power.**

















**Do not use the lighter exceeding 24 V, 100 W.**

## 2) RADIO AND USB PLAYER (WITH BLUETOOTH)



9403CD100

### FRONT PANEL PRESENTATION

















- |   |   |
|---|---|
| <p>1  ..... Power ON/OFF,<br/>Volume UP/DOWN button</p> <p>2  ..... Manual UP/DOWN Tuning,<br/>File search, SEL button</p> <p>3  ..... Mode button,<br/>Audio mute button</p> <p>4  ..... Call &amp; Pair button</p> <p>5  ..... Call end button</p> <p>6  ..... Station preset 1<br/>DIS ..... Display button</p> <p>7  ..... Station preset 2</p> <p>8  ..... Station preset 3<br/>RPT ..... Repeat play button</p> <p>9  ..... Station preset 4<br/>RDM ..... Random play button</p> | <p>10  ..... Station preset 5<br/>DIR- ..... Directory down button</p> <p>11  ..... Station preset 6<br/>DIR+ ..... Directory up button</p> <p>12  ..... Scan play button (SCAN)<br/>Best station memory (BSM) button</p> <p>13  ..... Auto tune up, Seek up button</p> <p>14  ..... Auto tune down, Track down button</p> <p>15  ..... USB connector</p> <p>16  ..... AUX IN Jack</p> <p>17  ..... MIC hole</p> |
|---|---|

## RADIO AND USB PLAYER (WITHOUT BLUETOOTH)



9403CD101

### FRONT PANEL PRESENTATION

- |  |   |
|--|---|
| <p>1  ..... Power ON/OFF,<br/>Volume UP/DOWN button</p> <p>2  ..... Manual UP/DOWN Tuning,<br/>File search, SEL button</p> <p>3  ..... Mode button,<br/>Audio mute button</p> <p>4  ..... Radio seek up button</p> <p>5  ..... Radio seek down button</p> <p>6  ..... Station preset 1<br/>DIS ..... Display button</p> <p>7  ..... Station preset 2</p> <p>8  ..... Station preset 3<br/>RPT ..... Repeat play button</p> <p>9  ..... Station preset 4<br/>RDM ..... Random play button</p> | <p>10  ..... Station preset 5<br/>DIR- ..... Directory down button</p> <p>11  ..... Station preset 6<br/>DIR+ ..... Directory up button</p> <p>12  ..... Scan play button (SCAN)<br/>Best station memory (BSM) button</p> <p>13  ..... Track up button</p> <p>14  ..... Track down button</p> <p>15  ..... USB connector</p> <p>16  ..... AUX IN Jack</p> |
|--|---|

## ■ GENERAL

### (1) Power and volume button



#### ① Power ON / OFF button

Press power button (1) to turn the unit on or off.

#### ② Volume UP/DOWN control knob

Turn VOL knob (1) right to increase the volume level.

Turn VOL knob (1) left to decrease the volume.

After 5 seconds the display will return to the previous display mode.

#### ③ Initial volume level set up

I-VOL is the volume level the unit will play at when it is next turned on. To adjust the I-VOL level, press and hold VOL button (1) for longer than 2 seconds. The current volume level displays on the display panel.

Then turn button (1) right or left to set the volume level as the I-VOL level.

#### ④ Clock ON/OFF control

The CLOCK was default at off status. To turn CLOCK ON, press and hold VOL button (1) for longer than 2 seconds to display I-VOL, then short press VOL again, turn VOL knob while CLOCK OFF display, then the CLOCK ON will be displayed.

※ Due to time tolerance, the clock display on the Audio unit might have slight difference.

#### ⑤ Clock adjustment

With CLOCK ON selected, press VOL knob again after CLOCK ON display, the hour will blink, turn VOL knob right or left to adjust hour.

Simply press VOL again, the minute will blink, turn VOL knob to adjust minute. Then press VOL again to confirm the clock once finished.



## (2) Menu Selection



- ① This button can adjust the effect of the sound and other things. Each time you press this button (2), LCD displays as follows :

BAS → TREB → BAL L=R → FAD F=R → EQ → LOUD ON → BEEP 2ND

On each setting, the level can be controlled by turning TUNE knob (2). When the last adjustment is made, after 5 seconds, the display will automatically return to the previous display mode.

### ② Bass control

To adjust the bass tone level, first select the bass mode by pressing SEL button (2) repeatedly until BASS appears on the display panel. Then turn knob (2) right or left within 5 seconds to adjust the bass level as desired. The bass level will be shown on the display panel from a minimum of BASS-7 to a maximum of BASS+7.

### ③ Treble control

To adjust the treble tone level, first select the treble mode by pressing SEL button (2) repeatedly until TREB appears on the display panel. Then turn knob (2) right or left within 5 seconds to adjust the treble level as desired. The treble level will be shown on the display panel from a minimum of TREB -7 to a maximum of TREB +7.

### ④ Balance control

To adjust the left-right speaker balance, first select the balance mode by pressing SEL button (2) repeatedly until BAL indication appears on the display panel. Then turn knob (2) right or left within 5 seconds to adjust the balance as desired. The balance position will be shown by the bars on the display panel from BAL 10R (full right) to BAL 10L (full left).

### ⑤ Fader control

To adjust the front-rear speaker balance, first select the fader mode by pressing SEL button (2) repeatedly until FADER indication appears on the display panel. Then turn knob (2) right or left within 5 seconds to adjust the front-rear speaker level as desired. The fader position will be shown by the bars on the display panel from FAD 10F (full front) to FAD 10R (full rear).

### ⑥ EQ control

You can select an equalizer curve for 4 music types (CLASSIC, POP, ROCK, JAZZ). Press button (2) until EQ is displayed, then turn knob (2) right or left to select the desired equalizer curve. Each time you turn the knob, LCD displays as follows :

EQ OFF → CLASSIC → POP → ROCK → JAZZ

- ※ When the EQ mode is activated, the BASS and TREBLE modes are not displayed.

### ⑦ Loud control

When listening to music at low volume levels, this feature will boost the bass and treble response. This action will compensate for the reduction in bass and treble performance experienced at low volume.

To select the loudness feature, press button (2) until LOUD is displayed, then turn knob (2) right or left to activate or deactivate loudness.

### ⑧ Beep control

To adjust the BEEP mode, first select the BEEP mode by pressing button (2) repeatedly until BEEP indication appears on the display panel. Then turn knob (2) left or right within 5 seconds to select BEEP 2ND, BEEP OFF or BEEP ON.

- BEEP 2ND : You will only hear the beep sound when the buttons are held down for more than 2 seconds.
- BEEP OFF : You can not hear the sound beep when you press the buttons.
- BEEP ON : You can hear the beep sound each time you press the buttons.

### (3) Mute control

- ① Press and hold MUTE button (3) for over 2 seconds to mute sound output and MUTE ON will blink on the LCD. Press the button again to cancel MUTE function and resume to normal playing mode.

### (4) Mode selection

- ① Repeat press MODE button (3) to switch between FM1, FM2, AM, USB, AUX, BT MUSIC.
- ※ If there is no USB, AUX, Bluetooth Phone connected, it would not display USB, AUX, BT when you press button (3).

## ■ RADIO

### (1) Mode button



- ① Repeat press MODE button to select FM1, FM2 or AM.

### (2) Manual tuning button



- ① To manually tune to a radio station, simply turn encoder TUNE (2) left or right to increase or decrease the radio frequency.

### (3) Auto tuning button



- ① To automatically select a radio station, simply press Seek up or Track down button.



### (4) Station preset button



- ① In radio mode, pressing buttons (6) to (11) will recall the radio stations that are memorized. To store desired stations into any of the 6 preset memories, in either the AM or FM bands, use the following procedure :

- a. Select the desired station.
- b. Press and hold one of the preset buttons for more than 2 seconds to store the current station into preset memory. Six stations can be memorized on each of FM1, FM2, and AM.

#### (5) Preset scan (PS) / Best station memory (BSM) button



① Press BSM button (12) momentarily to scan the 6 preset stations stored in the selected band. When you hear your desired station, press it again to listen to it.

Press BSM button (12) for longer than 2 seconds to activate the Best Station Memory feature which will automatically scan and enter each station into memory.

※ **If you have already set the preset memories to your favorite stations, activating the BSM tuning feature will erase those stations and enter into the new ones. This BSM feature is most useful when travelling in a new area where you are not familiar with the local stations.**

## ■ USB PLAYER

### (1) USB playback



- ① The unit was equipped with a front USB jack and also a rear USB Jack.

With a USB device plugged in the front USB jack, it will be detected as front USB mode. And with a USB device plugged in the rear USB jack, it will be detected as rear USB. To get to a USB mode, press MODE (3) button momentarily or insert the USB device in front or rear USB jack.

- ※ If there are no mp3 or wma files in USB device, it will revert to the previous mode after displaying NO FILE.

### (2) Track Up / Down button



- ① Press SEEK up (13) or TRACK down (14) to select the next or previous track. Press and hold the buttons to advance the track rapidly in the forward or backward direction.



### (3) MP3 directory / File searching



- ① Button (2) is used to select a particular directory and file in the device. Turn button (2) right or left to display the available directories. Press button (2) momentarily when the desired directory is displayed, then turn button (2) right or left again to display the tracks in that directory. Press button (2) to begin playback when the desired file is displayed.

### (4) Directory Up / Down button



- ① During MP3/WMA playback, simply press DIR- button (10) to select the previous directory (if available in the device); simply press DIR+ button (11) to select the next directory (if available in the device).

- ※ If the USB device does not contain directories, it would play MP3/WMA tracks at 10- file when you press DIR- button (10), and play MP3/WMA tracks at 10+ file when you press DIR+ (11) button.

#### (5) Track Scan Play (SCAN) button



- SCAN playback : Simply press SCAN (12) button to play the first 10 seconds of each track.
- SCAN folder : Press and hold SCAN button for longer than 2 seconds to scan play the tracks in current folder.
- SCAN off : Simply press it again to cancel SCAN feature.

#### (6) Track Repeat Play (RPT) button



- REPEAT playback : Simply press RPT (8) button to play current track repeatedly.
- REPEAT folder : Press and hold RPT for longer than 2 seconds to repeat play the tracks in current folder.
- REPEAT off : Simply press it again to cancel REPEAT feature.

#### (7) Track Random Play (RDM) button



- RANDOM playback : Simply press RDM (9) button to play the tracks in the device in a random sequence.
- RANDOM folder : Press and hold RDM button for longer than 2 seconds to randomly play the tracks in the current folder.
- RANDOM off : Simply press it again to cancel RANDOM feature.

#### (8) ID3 v2 (DISP)



- ① While a MP3 file is playing, press DISP button (6) to display ID3 information. Repeat push DISP button (6) to show directory name / file name and album name / performer / title.

※ If the MP3 disc does not have any ID3 information, it will show NO ID3.

\* USB Information and Notice

- a. Playback FILE SYSTEM and condition allowance.
    - FAT, FAT12, FAT16 and FAT32 in the file system.
    - V1.1, V2.2 and V2.3 in the TAG (ID3) version.
  - b. Display up to 32 characters in the LCD display.
  - c. No support any of MULTI-CARD Reader.
  - d. No high speed playback but only playing with normal full speed.
- ※ DRM files in the USB may cause malfunction to playback in the radio unit.
- ※ In temperatures below -10°C (14°F), the audio unit with USB hook up may be affected and not play well.

## ■AUX OPERATION

It is possible to connect your portable media player to the audio system for playback of the audio tracks via the cab speakers.

To get the best results when connecting the portable media to the audio system, follow these steps :

- Use a 3.5 mm stereo plug cable to connect the media player headphone socket at each end as follows.
  - Adjust the portable media player to approximately 3/4 volume and start playback.
  - Press the MODE button (3) on the audio unit to change into AUX mode.
  - The volume and tone can now be adjusted on the audio unit to the desired level.
- ※ The audio quality of your media player and the audio tracks on it may not be of the same sound quality as the audio system is CD Player.
- ※ If the sound of the media player is too low compared with the radio or CD, increase the volume of the player.
- ※ If the sound of the media player is too loud and/or distorted, decrease the volume of the player.
- ※ When in AUX mode, only the Volume, Bass, Treble, EQ and Mode functions of the audio unit can be used.

## ■ BLUETOOTH (if equipped)

### (1) Using a bluetooth wireless connection

- ① Your audio unit supports bluetooth wireless technology. You can set up a wireless link with bluetooth cellular phone.
  - ② Continue to pair the cellular phone with the audio unit. Within a few moments the two should be able to connect.
- ※ Since this audio unit is on standby to connect with your cellular phone via bluetooth wireless technology, using this audio unit without running the engine can result in battery drainage.
  - ※ This audio units phone call reception is on standby when ignition switch is set to ACC OFF or ON.
  - ※ The line-of-sight distance between this audio unit and your cellular phone must be 10 meters or less for sending and receiving voice and data via bluetooth wireless technology. However the transmission distance may become shorter than the estimated distance depending on the environment where it is being used.
  - ※ Digital Noise & Echo suppression system provides the best sound clarity with little or no distortion (Echo & side tone will happen depending on cellular phone or service network).
  - ※ To ensure the quality of calling, you should select a proper bluetooth VR level. This audio unit is already equipped with the best bluetooth VR level.

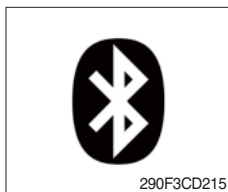

#### a. Bluetooth icon

It will blink while establishing the bluetooth pairing.  
It will light up after a bluetooth device connected.

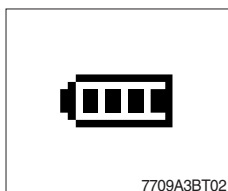

#### b. Battery icon

It indicates the battery status of the connected bluetooth device.



#### c. Single strength icon

It indicates the signal strength of the connected bluetooth device.



## (2) Pairing in hands free modes



- ① Press and hold CALL button (4) for 2 seconds until you hear beep sound, then PAIR STR will appear on the display.
- ② For the next procedure, go to cellular phone pairing mode.
- ③ If it is in pairing status with audio unit and cellular phone, PAIRING will show on the display.
- ④ If you want to exit pairing mode, press CALL END button (5) briefly while pairing, then it will show PAIR CLR on the display.
- ⑤ Bluetooth Icon and PAIR OK appear on the display when pairing is successful.

## (3) Cellular phone pairing mode

- ① Browse your cellular phone menu and find the connectivity or bluetooth connection section.
  - ② Select search for a new handsfree device function and allow the phone to find the mobile.
  - ③ HYUNDAI should appear on your cellular phone screen.
  - ④ Press connect menu among the handsfree option on your cellular phone.
  - ⑤ The cellular phone should prompt for a pin code. Insert the pin code 1234.
  - ⑥ The cellular phone should confirm that it has established a new paired connection.
  - ⑦ Close the menu. The pairing is now completed. It appears PAIR FAIL on the display for 3 seconds.
- ※ Each cellular phone type has distinct phone menu so you may need to refer to your manufactures instruction for the correct procedure on how to connect a new bluetooth device.
  - ※ Please retry the pairing instruction if HYUNDAI does not appear on the cellular phone screen.
  - ※ Please select authorized, if there is authorized menu in the menu of bluetooth connection in your cellular phone.
  - ※ Once the bluetooth pairing is completed between your cellular phone and this audio unit, both units will be automatically recognized on its paring like when you turn on the key in your car even though the audio unit is turned off.
  - ※ This audio unit can store up to 6 phones pairings. If the memory is full, the first stored paired phone will be deleted.
  - ※ The connecting priority will be given to the last connected cellular phone.
  - ※ If you want to change the connecting priority, try to connect this audio unit from the cellular phone you want.

#### (4) Bluetooth connection and disconnection



① When established bluetooth connection is made between this audio unit and the cellular phone, bluetooth icon on the display appears and then the display shows HF/AV CONN when handsfree & AV profile is connected.

② To disconnect bluetooth link  
Press and hold CALL END button (5) for 2 seconds, it shows DIS CON and bluetooth Icon disappears on the display.

③ To connect bluetooth link  
Press CALL button (4) briefly, it blinks bluetooth Icon on the display while bluetooth is being connected. If the connection is completed, bluetooth Icon displays on the display.

※ When your cellular phone battery is at low charge, the bluetooth connection may occasionally be lost. To maintain good connectivity ensure that your phone battery is adequately charged.

※ In case of failure of bluetooth pairing :

- Delete item in paired list on your phone.
- Reset both phone by power off/on and the audio unit by ACC off/on.

※ Connecting priority of handsfree profile is higher than headset profile.

※ The headset mode does not support caller ID, reject call and call Transfer.

#### (5) Using the audio unit as a handsfree device



① When the audio unit is ringing, it shows CALL and follows with the phone number \*\*\*\*\* on the display.

② To accept call  
Press CALL button (4), ANSWER CALL followed by TALKING will show in the display.

③ To end call  
To end call, press CALL END button (5), REJECT appears on the display.

※ If reject call is activated in your phone, then your cellular phone does not support reject call function.

### (6) Audio transfer between the audio unit and phone

The audio transfer function is for switching the call from the audio unit to the cellular phone for private conversation.



- ① Press CALL button (4) briefly during conversation, it appears CALL TRANS on the display. To switch back to the audio unit, press button (4) briefly during private conversation, then it appears CALL TRANS on the display again.
- ※ **This function will be a cause of disconnection of bluetooth link in some nokia phones, but do not worry, just press button (4) during private conversation, then switch back to the audio unit automatically.**
- ※ **The quality of calling between cellular phone and audio unit is better than calling between one audio unit and another one.**

### (7) Last call number dialing



- ① Press CALL button (4) briefly, it appears CALL TO on the display, then simply press CALL button once again, it would make the last call with phone number displayed on LCD.  
If Reject call is activated in your phone, then your cellular phone does not support Reject Call function.
- ※ **If you are using SAMSUNG phone, then you may need to press send button once more. With the first press of button it should show contact list in your phone, then if you press again you should be ready to make the last call.**

### (8) To make a call by cellular phone

The audio transfer function is for switching the call from the audio unit to the cellular phone for private conversation.

- ① The audio unit will be activated automatically when you make a call with cellular phone.
- ② When you make a call processing by cellular phone, it shows CALLING on the display.
- ③ When you receive a call, the phone number \*\*\*\*\* appears on the display.

### **(9) Using the audio unit as bluetooth music**





The audio unit supports A2DP (Audio Advanced Distribution Profile) and AVRCP (Audio Video Remote Control Profile), and both profiles are available to listen music at the audio unit via cellular phone which is supporting the two profiles above.

- ① To play music, search the menu on your cellular phone as below :  
i.e : Menu→ File manager→ Music→ Option→ Play via bluetooth.  
It appears BT MP3 on the display.
  - ② During BT MP3 playing, you could select the previous or next track by pressing SEEK up or TRACK down button on audio unit or operate via your cellular phone.
  - ③ To stop music, press button (5) briefly and it will automatically switch into the previous mode.
  - ④ To resume music playing, press the play button on your cellular phone.
- ※ **This function may be different depending on cellular phone. Please follow the cellular phone menu. Some types of phones need to pair once more for bluetooth MP3 connection.**
  - ※ **This function will be caused to disconnect A2DP, AVRCP depends on cellular phone.**
  - ※ **Information about songs (e.g.: the elapsed playing time, song title, song index, etc.) cannot be displayed on this audio unit.**

## ■ RESET AND PRECAUTIONS

### (1) Reset function

Interfering noise or abnormal compressed files in the MP3 disc or USB instrument may cause intermittent operation (or unit frozen/locking up). It is strongly recommended to use appropriate USB storage to not cause any malfunction to the audio unit. In the unlikely event that the player fails to operate correctly, try to reset unit by any of following two methods.

- ① press and hold   simultaneously for about 5 seconds. (without Bluetooth)
- ② Press and hold   simultaneously for about 5 seconds. (with Bluetooth)

※ Take out the fuse for the audio system in the vehicle once and then plug it back in.

※ It will be necessary to re-enter the radio preset memories as these will have been erased when the microprocessor was reset.

After resetting the player, ensure all functions are operating correctly.

### (2) Precautions

When the inside of the cab is very cold and the player is used shortly after switching on the heater, moisture may form on the disc or the optical parts of the player and proper playback may not be possible.

If moisture forms on the optical parts of the player, do not use the player for about one hour. The condensation will disappear naturally allowing normal operation.

- ① Operation voltage : 9~32 volts DC, negative
- ② Output power : 40 watts maximum (20 watts x 2 channels)
- ③ Tuning range

Area	Band	Frequency range	Step
USA	FM	87.5~107.9 MHZ	200K
	AM	530~1710 KHZ	10K
EUROPE	FM	87.5~108.0 MHZ	50K
	AM	522~1620 KHZ	9K
ASIA	FM	87.5~108.0 MHZ	100K
	AM	531~1602 KHZ	9K
LATIN	FM	87.5~107.9 MHZ	100K
	AM	530~1710 KHZ	10K

#### ● AREA Selection :

- To select an area, press and hold related buttons at FM1 band for about 3 seconds.
- USA Area: Press and hold mode + 1DIS buttons for 3 seconds
- EUROPE Area: Press and hold mode + 2 buttons for 3 seconds
- ASIA Area: Press and hold mode + 3RPT buttons for 3 seconds
- LATIN Area: Press and hold mode + 4RDM buttons for 3 seconds.

- ④ USB version : USB 1.1
- ⑤ Bluetooth version : V2.1
- ⑥ Bluetooth supported profile :
  - A2DP : Advanced Audio Distribution Profile
  - AVRCP : Audio/Video Remote Control Profile
  - HFP : Hands-Free Profile

### 3) SEAT

The seat is adjustable to fit the contours of the operator's body. It will reduce operator fatigue due to long work hours and enhance work efficiency.

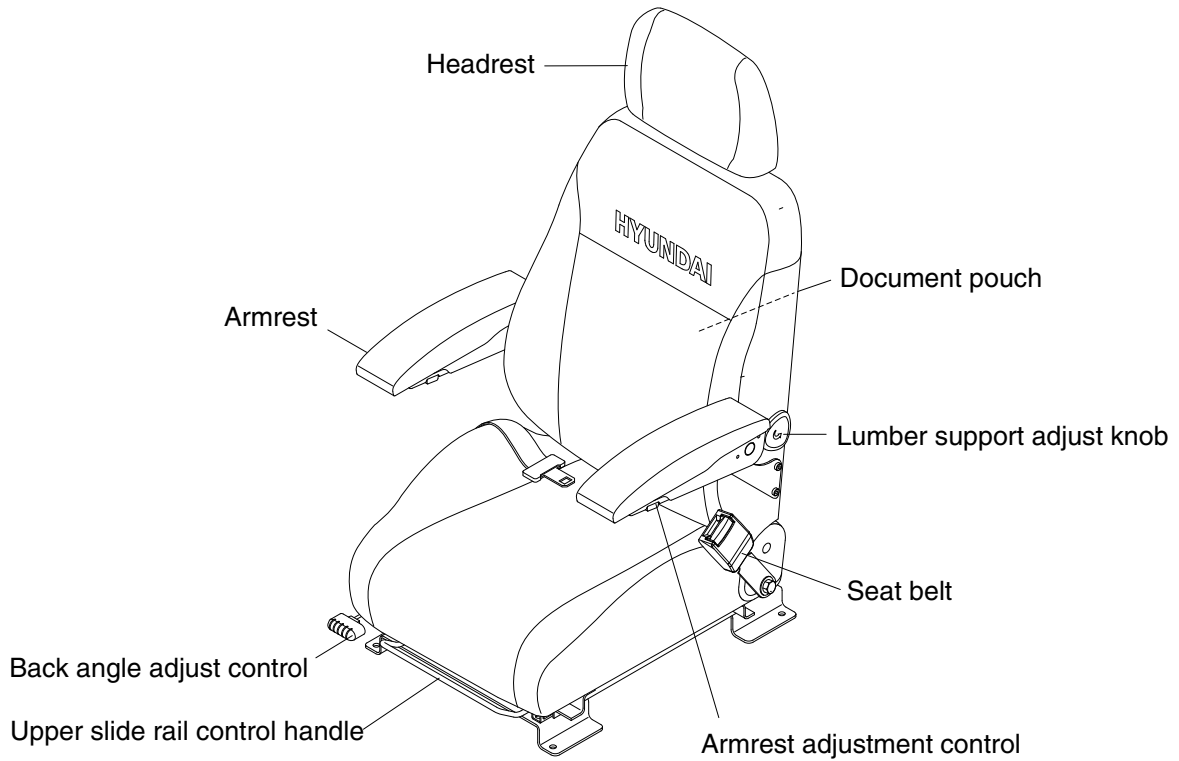

220S3CD270

#### 4) FUSE & RELAY BOX

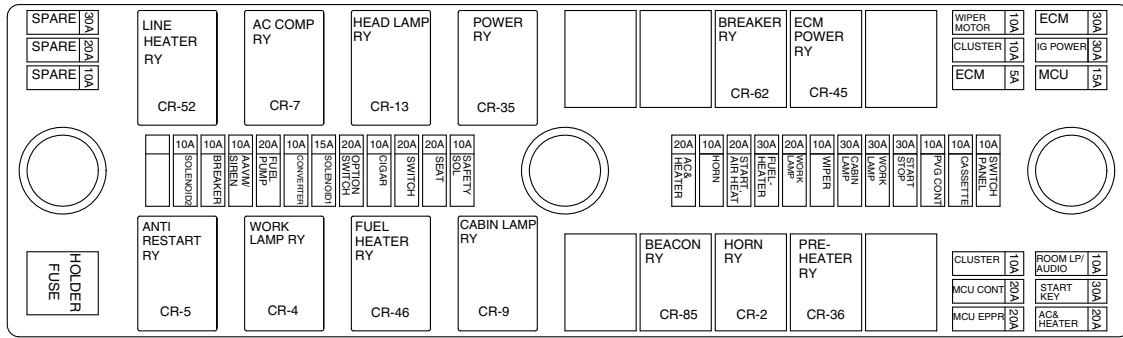

140SA3FR01

- (1) The fuses protect the electrical parts and wiring from burning out.
- (2) The fuse box cover indicates the capacity of each fuse and which circuit it protects.

※ **When replacing a fuse or relay, always use one of the same capacity.**

▲ **Before replacing a fuse, be sure to turn OFF the starting switch.**

#### 5) MCU

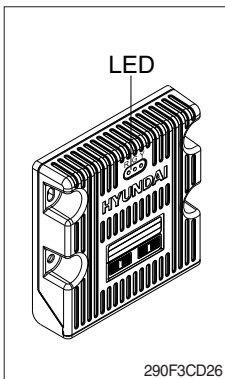

- (1) To match the pump absorption torque with the engine torque, MCU varies EPPR valve output pressure, which controls pump discharge volume whenever engine speed drops and provides feedback, under the reference rpm of each mode set.
- (2) Three LED lamps on the MCU display as below.

LED lamp	Trouble	Service
G is turned ON	Normal	-
G and R are turned ON	Trouble on MCU	· Change the MCU
G and Y are turned ON	Trouble on serial communication line	· Check if serial communication lines between controller and cluster are disconnected
Three LED's are turned OFF	Trouble on MCU power	· Check if the input power wire (24 V, GND) of controller is disconnected · Check the fuse

G : green, R : red, Y : yellow

## 6) SERVICE METER

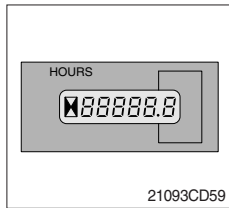

- (1) This meter shows the total operation hours of the machine.
- (2) Always ensure the operating condition of the meter during the machine operation. Inspect and service the machine based on hours as indicated in chapter 6, maintenance.

## 7) RS232 SERVICE SOCKET CONNECTOR

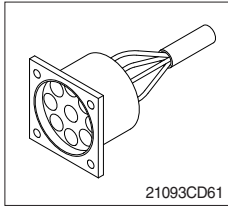

- (1) MCU communicates the machine data with Laptop computer through the RS232 service socket.

## 8) 12V SOCKET

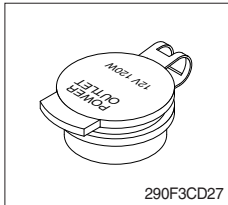

- (1) Utilize the power of 12 V as you need and do not exceed 12 V, 30 W.

## 9) UPPER WINDSHIELD

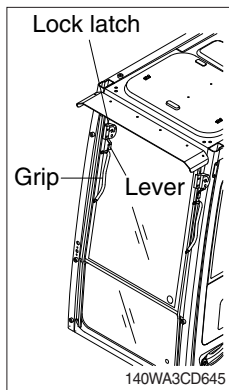

- (1) Perform the following procedure in order to open the upper windshield.
  - ① Pull both levers on the lock latch and hold both grips that are located at the top of the windshield frame and push the windshield upward.
  - ② Hold both grips and pull back into the lock position until the striker is engaged, then release the grips.

**▲ When working, without having locked the windshield by the striker (by pushing the windshield to the rear until it's completely fixed), please be careful as it can cause personal injury if the windshield is not fixed or falls off.**

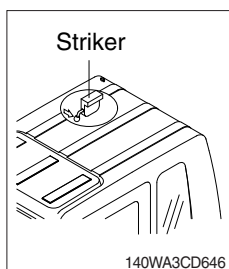

- (2) Perform the following procedure in order to close the upper windshield.
  - ① Pull the lever of the auto lock latch in order to release the from the striker.
  - ② Steps in the reverse order to close the upper windshield.



## 10) EMERGENCY ENGINE SPEED CONTROL CONNECTOR

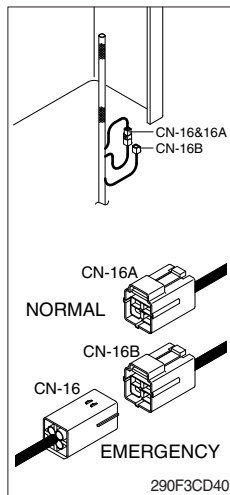

(1) When the CAN communication between the ECM and the MCU is abnormal due to malfunction, change the CN-16 connection from CN-16A to CN-16B and then control the engine speed by rotating the multimodal module of the jog dial module.

- ※ **Never connect connector CN-16 with CN-16B when MCU is in normal operation.**
- ※ **Make repair as soon as possible.**